

Instruction Manual

ZEISS Axiolab 5, Axiolab 5 materials

Upright Microscope for Routine and Entry-level Research



ZEISS Axiolab 5, Axiolab 5 materials

Original Manual

EC	REP
-----------	------------

Carl Zeiss Microscopy GmbH
Carl-Zeiss-Promenade 10
07745 Jena
Germany
info.microscopy.de@zeiss.com
www.zeiss.com/microscopy

CH	REP
-----------	------------

Carl Zeiss AG
Feldbachstr. 81
8714 Feldbach
Switzerland

UK Responsible Person

Carl Zeiss Ltd
1030 Cambourne Business Park, Cambourne
CB23 6DW Cambridge
United Kingdom



Carl Zeiss Suzhou Co., Ltd.
Modern Industrial Square 3-B, No.333 XingPu Road SIP
215126 Suzhou
China

Document Name: Instruction Manual ZEISS Axiolab 5, Axiolab 5 materials

Order Number: 430037-7444-001

Revision: 9

Language: en-US

Effective from: 04/2023



© 2023 Without the prior written consent of ZEISS, this document or any part of it must neither be translated nor reproduced or transmitted in any form or by any means - including electronic or mechanic methods, by photocopying, recording or by any information or filing system. The right to make backup-copies for archiving purposes shall remain unaffected thereby. Any violations may be prosecuted as copyright infringements.

The use of general descriptive names, registered names, trademarks, etc. in this document does not imply that such names are exempt from the relevant intellectual property laws and regulations and therefore free for general use. This shall also apply if this is not specifically referred to. Software programs shall entirely remain the property of ZEISS. No program or subsequent upgrade thereof may be disclosed to any third party, copied or reproduced in any other form without the prior written consent of ZEISS, even if these copies or reproductions are destined for internal use at the customer's only, the only exception being one single back-up copy for archiving purposes.

Table of Contents

1	About this Instruction Manual	7
1.1	Text Conventions and Link Types	7
1.2	Explanation of Warning Messages and Additional Information.....	8
1.3	Explanation of Symbols	9
1.4	Further Applicable Documents	10
1.5	Contact.....	10
2	Safety	11
2.1	Intended Purpose.....	11
2.2	General Safety Information	12
2.2.1	Requirements for Operators	12
2.2.2	Safe Operating Condition.....	12
2.2.3	Order and Use of Spare Parts	12
2.2.4	EMC Information.....	13
2.2.5	Optical Risk Grouping.....	13
2.2.6	Lifetime.....	13
2.3	Prevention of Hazards	14
2.3.1	Mechanical Hazards	14
2.3.2	Electrical Hazards	14
2.3.3	Hazards Generated with the Operating Environment.....	14
2.3.4	Ergonomic Hazards	14
2.3.5	Hazards Generated by Materials and Substances.....	15
2.3.6	Hazards Generated by Radiation	15
2.3.7	Thermal Hazards	16
2.4	Labels and Lights	16
2.4.1	Labels on the Axiolab 5	16
2.5	Safety Devices and Interlocks	17
3	Product and Functional Description	18
3.1	Main Components	19
3.1.1	Axiolab 5 Bio-TL.....	19
3.1.2	Axiolab 5 Bio-TL/FL	20
3.1.3	Axiolab 5 Pol-TL	20
3.1.4	Axiolab 5 Pol-TL/conoscopy.....	21
3.1.5	Axiolab 5 Pol-TL/RL	21
3.1.6	Axiolab 5 Mat-TL/RL.....	22
3.2	Controls and Functional Elements on Components.....	23
3.2.1	Axiolab 5 Bio-TL Stand	23
3.2.2	Axiolab 5 Bio-TL/FL Stand.....	24
3.2.3	Axiolab 5 Pol-TL Stand	25
3.2.4	Axiolab 5 Pol-TL/conoscopy Stand.....	26
3.2.5	Axiolab 5 Pol-TL/RL Stand	27
3.2.6	Axiolab 5 Mat-TL/RL Stand	29
3.2.7	Functions of Stand Keys and Display Elements.....	30
3.2.8	Binocular Tubes.....	31
3.2.9	Eyepieces	34
3.2.10	Eyepieces with Eyepiece Reticles	34
3.2.11	Nosepiece with Objectives	35
3.2.12	Condenser Carrier	35
3.2.13	Condensers	36

3.2.14	Stages	37
3.2.15	Reflector Turret	38
3.2.16	Storage Compartment	39
3.3	Light Manager Function	39
3.4	Microscopy and Contrast Techniques	40
3.4.1	Transmitted Light Brightfield Microscopy Using the KÖHLER Method	40
3.4.2	Transmitted Light Darkfield Microscopy Using the KÖHLER Method	40
3.4.3	Transmitted Light Phase Contrast Microscopy	40
3.4.4	Transmitted Light Polarization	41
3.4.5	Transmitted Light Polarization for Conoscopic Observation	45
3.4.6	Reflected Light Brightfield Microscopy Using the KÖHLER Method	45
3.4.7	Reflected Light Darkfield Microscopy Using the KÖHLER Method	46
3.4.8	Reflected Light Polarization Microscopy	46
3.4.9	Reflected Light Fluorescence Microscopy	46
4	Installation	47
4.1	Unpacking and Setting Up the Microscope	47
4.2	Assembling the Binocular Tube	48
4.3	Assembling the Binocular Tube with an Intermediate Plate	49
4.4	Assembling Components to the Binocular Tube	50
4.5	Assembling Objectives	51
4.6	Assembling Condensers	52
4.6.1	Assembling the Condenser 0.9/1.25 BF, DF, Ph1, Ph2, Ph3 with Modulator Disk	52
4.6.2	Assembling the Dry Darkfield Condenser	53
4.6.3	Assembling the Condenser, Chromatic-aplanatic 0.9 BF DF PhC DIC	54
4.6.4	Assembling the Modulator Disk in the Condenser 0.9 BF Pol	55
4.7	Loading the Reflector Turret	56
4.7.1	Assembling Reflector Modules	56
4.7.2	Removing Reflector Modules	57
4.8	Connecting the Microscope to the Mains	57
5	Operation	58
5.1	Prerequisites for Commissioning and Operation	58
5.2	Switching On the Microscope	58
5.3	Adjusting	59
5.3.1	Adjusting the Position of the Eyepieces	59
5.3.2	Adjusting for Ametropia when Using Eyepiece Reticles	59
5.3.3	Adjusting the Height Stop on the Condenser Carrier	60
5.3.4	Using the Light Manager Function	61
5.3.5	Setting the ECO/Permanent Mode	62
5.4	Setting Up for Transmitted Light Techniques	63
5.4.1	Setting Up for Transmitted Light Brightfield Microscopy	63
5.4.2	Setting Up for Transmitted Light Darkfield Microscopy	66
5.4.3	Setting Up for Transmitted Light Phase Contrast Microscopy	69
5.4.4	Setting Up for Transmitted Light Polarization	69
5.5	Setting Up for Reflected Light Techniques	78
5.5.1	Setting Up for Reflected Light Brightfield Microscopy	78
5.5.2	Setting Up for Reflected Light Darkfield Microscopy	81
5.5.3	Setting Up for Reflected Light Polarization Microscopy	82
5.5.4	Setting Up for Reflected Light Fluorescence Microscopy	84
5.6	Switching Off the Microscope	87

6	Care and Maintenance	88
6.1	Safety During Cleaning and Maintenance.....	88
6.2	Maintenance Schedule	89
6.3	Maintenance Work	89
6.3.1	Cleaning an Optical Surface	89
6.3.2	Removing Water-Soluble Contamination	90
6.3.3	Exchanging the Fuses T 15 A/H 250 V	90
6.3.4	Mechanical Stages	91
7	Troubleshooting	93
7.1	Resetting the Microscope to Factory Settings	96
8	Decommissioning and Disposal.....	97
8.1	Decommissioning.....	97
8.2	Transport and Storage	97
8.3	Disposal	98
8.4	Decontamination	98
9	Technical Data and Conformity.....	99
9.1	Performance Data and Specifications	99
9.2	Applicable Standards and Regulations.....	101
10	Accessories and System Expansions.....	103
10.1	Assembling the Reversible Eyecups.....	105
10.2	Binocular Tubes	105
10.2.1	Binocular Tube 30°/23	105
10.2.2	Binocular Photo Tube Pol 20°/23 (100:0/0:100).....	106
10.2.3	Binocular Ergo Photo Tube 20°/23 (100:0/0:100)	107
10.3	Stages.....	108
10.3.1	Assembling a Mechanical Stage and Sample Holder	108
10.3.2	Removing a Mechanical Stage and Sample Holder	109
10.3.3	Rackless Mechanical Stage, 75x30 R	110
10.3.4	Mechanical Stage, 75x30 R.....	111
10.3.5	Rotary Stage Pol 360° with Sample Guide.....	112
10.4	Analyzer Sliders.....	117
10.4.1	Analyzer Slider TL/RL, Fixed	117
10.4.2	Analyzer Slider TL/RL, with Lambda Plate, 360° Rotatable	117
10.4.3	Analyzer Slider TL/RL with Lambda Plate, each Rotatable +/- 10°	117
10.5	Polarizers	118
10.5.1	Polarizer D, Fixed, Removable	118
10.5.2	Polarizer D, 90°, Rotatable, Removable	118
10.5.3	Polarizer, Fixed, with Lambda Plate, Rotatable	119
10.5.4	Polarizer, Rotatable, with Color Filter Carrier	119
10.5.5	Circular Polarizer D.....	120
10.5.6	Low-power System for Objectives 2.5x/4x.....	120
10.5.7	Color Filter Carrier 3x for Filter d=32mm	122
10.5.8	Assembling Polarizer or Color Filter Carrier onto the Condenser Carrier	122
10.6	DIC Slider C 6x20	123

10.7	Condenser, achromatic-aplanatic 0.9 BF DF PhC DIC	123
10.7.1	Assembling the Condenser, achromatic-aplanatic 0.9 BF DF PhC DIC	124
10.7.2	Centering the Darkfield Diaphragm of the Condenser	125
10.7.3	Centering the Annular Phase Diaphragm of the Condenser	125
10.8	Light Source for Transmitted Light	126
10.8.1	Removing the Cover (Transmitted Light Source)	126
10.8.2	Exchanging the Halogen Lamp	127
10.8.3	Exchanging the LED Light Source	128
10.9	Light Source for Reflected Light	130
10.9.1	Removing the Cover (Reflected Light Source)	130
10.9.2	Exchanging the Halogen Lamp	131
10.9.3	Exchanging the LED Light Source	131
10.9.4	Exchanging the LED Modules of the Fluorescence Light Source	134
10.10	Axiocam 202 Mono/208 Color	136
10.10.1	Assembling the Axiocam 202 mono or Axiocam 208 color	137
10.10.2	Operating Modes Using the Axiocam 202 mono/208 color	138
10.11	Assembling the Filter 32x4 mm on the Luminous-field Diaphragm Operating Ring	143
11	Revision History	144
	Glossary	145
	Index	146

1 About this Instruction Manual

This Instruction Manual (further called "document") is considered to be part of the Axiolab 5, Axiolab 5 materials, herein after referred to as "microscope".

This document contains basic steps and safety information that must be observed during operation and maintenance. Therefore, the document must be read by the operator prior to commissioning and must always be available at the place of use of the microscope.

This document is an essential part of the microscope and, if the microscope is resold, the document must remain with the microscope or be handed over to the new owner.

Axiolab 5 microscopes include:

- Axiolab 5 Bio-TL (430037-9011-000, 430037-9110-000, 430037-9060-000)
- Axiolab 5 Bio-TL/FL (430037-9021-000, 430037-9120-000, 430037-9070-000)
- Axiolab 5 Pol-TL (430037-9130-000)

Axiolab 5 materials microscopes include:

- Axiolab 5 Pol-TL/conoscopy (430037-9042-000)
- Axiolab 5 Pol-TL/RL (430037-9032-000)
- Axiolab 5 Mat-TL/RL (430037-9052-000)

1.1 Text Conventions and Link Types

Explanation	Example
Software controls and GUI elements.	Click Start .
Hardware controls and elements.	Press the Standby button.
Key on the keyboard.	Press Enter on the keyboard.
Press several keys on the keyboard simultaneously.	Press Ctrl + Alt + Del .
Follow a path in the software.	Select Tools > Goto Control Panel > Airlock .
Text to be entered by the user.	Enter <i>example.pdf</i> in this field.
Anything typed in literally during programming, for example macro codes and keywords.	Enter <code>Integer</code> in the console.
Link to further information within this document.	See: <i>Text Conventions and Link Types</i> [▶ 7].
Link to a website.	https://www.zeiss.com/corporate/int/home.html

1.2 Explanation of Warning Messages and Additional Information

DANGER, WARNING, CAUTION, and NOTICE are standard signal words used to determine the levels of hazards and risks of personal injury and property damage. Not only the safety and warning messages in the **Safety** chapter are to be considered also all safety and warning messages in other chapters. Failure to comply with these instructions and warnings can result in both personal injury and property damage and involve the loss of any claims for damages.

The following warning messages indicating dangerous situations and hazards are used in this document.

DANGER

Type and source of danger

DANGER indicates an imminently hazardous situation which, if not avoided, will result in death or serious injury.

WARNING

Type and source of danger

WARNING indicates a potentially hazardous situation which, if not avoided, may result in death or serious injury.

CAUTION

Type and source of danger

CAUTION indicates a potentially hazardous situation which, if not avoided, may result in minor or moderate injury.

NOTICE













Type and source of danger

NOTICE indicates a potentially harmful situation which, if not avoided, may result in property damage.

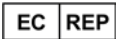
Info

Provides additional information or explanations to help the operator better understand the contents of this document.

1.3 Explanation of Symbols

	CE marking (Conformité Européene)
	CSA label: product tested by CSA to meet U.S. and Canadian standards. CSA approval master number optionally given adjacent to this symbol
	UKCA marking (UK conformity assessed)
	Manufacturer
	Country of manufacture. "CC" is the country code, e.g. "DE" for Germany, "CN" for China. Date of manufacture optionally given adjacent to this symbol
	Importer
	Authorized representative in the European Community
	Swiss authorized representative
	In-vitro diagnostic medical device
	Serial number
	Catalogue number
	WEEE label: Do not discard as unsorted waste. Send to separate collection facilities for recovery and recycling

1.4 Further Applicable Documents

Please take also note of the following documents:

Brochures and Certificates	For brochures, certificates (e.g. ISO, CSA, SEMI), and declarations of conformity (e.g. EU, UK) ask your ZEISS Sales & Service Partner.
Local and National Health and Safety Regulations	Observe local and national health and safety regulations for the location of installation and during the use of the microscope. Consult with your ZEISS Sales & Service Partner if these regulations are in conflict with the installation requirements of the microscope.
Software	For detailed information on how to use Microscopy Apps, refer to its manual (e.g. Online Help, Software Manual) or ask your ZEISS Sales & Service Partner.
System and Third-Party Components, Accessories	Information about the individual components, enhancements, and accessories can be obtained from your ZEISS Sales & Service Partner. Also refer to the documentation of third-party manufacturers. <ul style="list-style-type: none"> ▪ Axiocam 202 mono ▪ Axiocam 208 color ▪ Multidiscussion Units

1.5 Contact

If you have any questions or problems, contact your local ZEISS Sales & Service Partner or one of the following addresses:

Headquarters

Phone: +49 1803 33 63 34

Fax: +49 3641 64 3439

Email: info.microscopy.de@zeiss.com

Microscopy Courses, Training, and Education

For information on microscopy courses, training, and education contact us on our homepage (<https://www.zeiss.com/microscopy/int/service-support/training-and-education.html#contact>).

ZEISS Portal

The ZEISS Portal (<https://portal.zeiss.com/>) offers various services that simplify the daily work with your ZEISS systems (machines and software). It is constantly improved and extended to meet your needs and requirements better.

ZEISS Sales & Service Partner

You can find a ZEISS Sales & Service Partner in your area under <https://www.zeiss.com/microscopy/int/website/forms/sales-and-service-contacts.html>.

Service Germany

Phone: +49 7364 20 3800

Fax: +49 7364 20 3226

Email: service.microscopy.de@zeiss.com

2 Safety

This chapter contains general requirements for safe working practices. Any person using the microscope or commissioned with installation or maintenance must read and observe these general safety instructions. Knowledge of basic safety instructions and requirements is a precondition for safe and fault-free operation. Operational safety of the supplied microscope is only ensured if it is operated according to its intended use.

If any work is associated with residual risks, this is mentioned in the relevant parts of this document in a specific note. When components must be handled with special caution, they are marked with a warning label. These warnings must always be observed.

Any serious incident that has occurred in relation to the microscope and its components shall be reported to these institutions:

- the competent authority of the Member State in which the user is established
- ZEISS
 - for users within the EU:
Carl Zeiss Microscopy GmbH, Jena, Germany
 - for users outside the EU:
Carl Zeiss Suzhou Co., Ltd., Suzhou, China

2.1 Intended Purpose

The microscopes Axiolab 5 are instruments for general microscopic imaging for the in vitro-examination of various biological samples including samples collected from humans or animals. This imaging provides information to further assess physiological and pathological conditions.

The microscopes are intended to be used by trained professionals only.

Axiolab 5 microscopes include:

- Axiolab 5 Bio-TL (430037-9011-000, 430037-9110-000, 430037-9060-000)
- Axiolab 5 Bio-TL/FL (430037-9021-000, 430037-9120-000, 430037-9070-000)
- Axiolab 5 Pol-TL (430037-9130-000)

The Axiolab 5 materials microscopes are universally usable microscopes for applications such as materials analyses. It is not intended to either directly or indirectly generate medical diagnostic results.

Axiolab 5 materials microscopes include:

- Axiolab 5 Pol-TL/conoscopy (430037-9042-000)
- Axiolab 5 Pol-TL/RL (430037-9032-000)
- Axiolab 5 Mat-TL/RL (430037-9052-000)

Info

The catalogue number can be found on the type plate, see *Labels and Lights* [▶ 16].

Improper use of the microscope and its components can easily lead to impairment of their function or even damage them. Damage caused by incorrect operation, negligence, or unauthorized intervention, in particular by removing, modifying, or replacing parts of the microscope or its components, cannot be held liable by the device manufacturer. Third-party devices or components that are not expressly approved by ZEISS may not be used.

2.2 General Safety Information

This document must be read before commissioning in order to ensure safe and uninterrupted operation. Pay particular attention to all listed safety notes. Make sure, that

- the operating personnel has read and understood this manual, associated documents and particularly all safety regulations and instructions, and applies them.
- the local and national safety and accident prevention regulations must be observed, as well as the applicable laws and regulations in your country.
- this document is always available at the place of use of the microscope.
- the microscope is always in perfect condition.
- the microscope is secured against access by unauthorized persons.
- maintenance and repair work, retrofitting, removal or replacement of components, as well as any other intervention in the microscope not described in this document, may only be carried out by the manufacturer ZEISS or persons expressly authorized by ZEISS to do so.

2.2.1 Requirements for Operators

The microscope, components, and accessories may only be operated and maintained by authorized and trained personnel. The microscope may only be used in accordance with this document. If the microscope is not used as described, the safety of the user may be impaired and/or the microscope may be damaged.

Any unauthorized intervention or use other than within the scope of the intended use shall void all rights to warranty claims. The regional regulations on health protection and accident prevention must be observed at all times and during all work on and with the microscope.

Training Authorized ZEISS personnel will provide basic training in operating the microscope, as well as information on equipment safety and maintenance work that can be conducted by the operator. The training will be documented by ZEISS and its completion is to be confirmed by the operator.

Special application training is offered for a fee. Current training dates, additional information and the registration form can be found at <https://www.zeiss.com/microscopy/int/service-support/training-and-education.html>.

2.2.2 Safe Operating Condition

If circumstances occur which impair safety and cause changes in operating behavior, the microscope must be shut down immediately and a ZEISS service representative should be informed.

The microscope may only be operated if the operating conditions are adhered to.

- Do not operate the microscope until you have completely read and understood the entire documentation.
- Make sure that all protective cover panels are installed and all warning labels are available and legible.
- Ensure conditions and take measures to prevent the build up of electrostatic charge on the workplace.

2.2.3 Order and Use of Spare Parts

Using spare parts that are not provided by ZEISS can be hazardous or can lead to property damage.

- Unless authorized by ZEISS, all spare parts should be installed by a ZEISS service representative.
- Contact your ZEISS service representative for information on spare parts order.
- Only genuine parts supplied by ZEISS are to be used in servicing the microscope.

2.2.4 EMC Information

Axiolab 5 microscopes are intended to be used in home healthcare environment.

Axiolab 5 materials microscopes are intended to be used in an industrial electromagnetic environment.

If it is suspected that performance is affected by electromagnetic interference correct operation may be restored by increasing the distance between the equipment and the source of the interference.

Use of this microscope in a dry environment, especially if synthetic materials are present (synthetic clothing, carpets, etc.), may cause electrostatic discharges that may cause erroneous results.

The EMC performance has been verified as Class 1B for electromagnetic interference (EMI) according to CISPR 11 and basic electromagnetic environment for electromagnetic susceptibility (EMS) under the standardized configurations. There might be a degradation while an external component/accessory incorporated.

The following EMC user notice is for Korea only:

기종별	사용자안내문
B급기기 (가정용 방송통신기자재)	이 기기는 가정용(B급) 전자파적합기기로서 주로 가정에서 사용하는 것을 목적으로 하며, 모든 지역에서 사용할 수 있습니다.

If in doubt, contact a ZEISS service representative.

2.2.5 Optical Risk Grouping

According to EN 62471 sources of optical radiation are classified into risk groups subject to their potential photobiological hazard. Sources are classified into the following four groups according to hazard, based on the emission limit as well as permissible exposure time before hazard exceeded.

Risk group	Description
Exempt	No photobiological hazard.
1	No hazard due to normal behavioural limitations on exposure.
2	No hazard due to the aversion response to very bright light sources or thermal discomfort.
3	Hazardous even for momentary exposure.

The following table lists the risk grouping of the available light sources/illumination units according to the mentioned standard:

Light source/Illumination unit	Risk group
LED module 385 nm	3 (high risk)
LED modules 470 nm, 505 nm, 565 nm, 625 nm	2 (moderate risk)

2.2.6 Lifetime

A microscope is an opto-electronic device. Its availability for use is significantly determined by the performed maintenance. ZEISS guarantees the ability for maintenance and repair within eight years after initial operation. This is ensured by a corresponding service and spare parts concept, thus enabling the intended purpose within this duration.

2.3 Prevention of Hazards

This section summarizes potential hazards and recommended safety precautions. Failure to follow the safety instructions and instructions may result in personal injury and property damage.

2.3.1 Mechanical Hazards

- Property Damage due to Transport** There is a risk of injury and property damage if the microscope is improperly handled and transported.
- Only use the handle, if applicable, for transport of the microscope. Otherwise hold the microscope with one hand and the base plate with the other hand.

2.3.2 Electrical Hazards

- Voltage Hazards** Risk of electric shock in case of contact with live parts.
- The microscope must be plugged into a properly installed power socket with protective earth contact using the supplied mains cable. The protective earth connection must not be impaired by the use of extension cables.
- Detachable mains supply cords must not be replaced with inadequately rated cords. Always use the power cords supplied by ZEISS. When an unsuitable power cord is used, ZEISS can no longer guarantee the electrical safety and functionality of the microscope.
- Shut down the microscope when not using the microscope.
 - Disconnect the power supply before cleaning.
 - Set up and operate the microscope so that the connectors are easily accessible.
 - Position the microscope in a way so that you can easily unplug the power cable at any time.

2.3.3 Hazards Generated with the Operating Environment

- Explosion Hazard** Do not operate the devices included in the scope of supplies in a potentially explosive atmosphere, in the presence of volatile anesthetics or flammable solvents such as alcohol, gasoline or similar substances.
- Do not hold any flammable or easily combustible materials into the light beam.
- Dirt, Dust, and Moisture** Dirt, dust, and moisture can impair the microscope's functionality.
- Shut down the microscope whenever it is not used and cover it with a dust protection cover.
 - Always cover unused openings/ports with the corresponding system component or with blind caps.
 - Regular maintenance and cleaning according to the instructions in this document and according to the instructions in the associated stand manual.
 - Never expose the microscope to inadmissible climate conditions (high humidity and temperature).

2.3.4 Ergonomic Hazards

- Prevention of Musculoskeletal Disorders** Musculoskeletal disorders (MSDs) affect the muscles, nerves, blood vessels, ligaments and tendons. Workers in many different industries and occupations can be exposed to risk factors at work, such as lifting heavy items, bending, reaching overhead, pushing and pulling heavy loads, working in awkward body postures and performing the same or similar tasks repetitively. Employers are responsible for providing a safe and healthful workplace for their workers.

2.3.5 Hazards Generated by Materials and Substances

- Infection Hazards** Direct contact with the eyepieces can be a potential way of passing on bacterial and viral infections.
- The risk can be lowered by using personal eyepieces or eyecups. If eyepieces need to be disinfected frequently, ZEISS recommends to use the eyepieces without eyecups.
 - To avoid infections, the use of personal protective equipment (PPE), e.g. gloves, for operation, cleaning, and decontamination is highly recommended. Disposable gloves can be decontaminated with alcohol for example, if necessary, or should be changed frequently to minimize the risk of contamination.
- Biological Hazard** Biological substances/agents may pose a risk to the health of humans and other living organisms.
- Keep a logbook of the known biological substances/agents used when working with the microscope and show it to the ZEISS service representative before they perform any work on the microscope.
- Consumable Hazards** Incorrect handling of consumables and cleaning agents can lead to property damage or skin and eye injuries. Consumables that are not approved by ZEISS can lead to property damage. Consult your ZEISS Sales & Service Partner to learn what consumables you can order and how to handle them.
- Hazard of Skin Irritation** The immersion fluid can cause skin irritation.
- Avoid any contact with skin, eyes and clothes.
 - Read and observe the safety data sheet of the immersion fluid.
 - In the event of skin contact, wash the oil off with plenty of water and soap.
 - In the event of eye contact, flush eyes with copious amounts of water for a minimum of 5 minutes. See a medical specialist if the irritation persists.
- Hazardous Substances** The microscope and other components can come into contact with various specimens and substances that can be hazardous to humans and the environment.
- Make sure that the microscope was not in contact with hazardous substances (check the laboratory logbook); otherwise, the microscope must be cleaned/decontaminated/disinfected.
 - Check the components also. If necessary, clean the components as meticulously as possible. Label contaminated/infected components that cannot be properly cleaned.
 - Contaminated parts shall not be returned to any ZEISS department. Decontaminated parts can be sent to ZEISS accompanied by a signed „Customer Declaration of Decontamination“.
 - Wear gloves.

2.3.6 Hazards Generated by Radiation

- Optical Radiation Hazards** Gas discharge lights, LED lights and other sources of white light emit strong optical radiation (e.g. UV, VIS, IR). Optical radiation may cause damage to the skin and eyes. The extent of the damage depends on the parameters such as wavelength, exposure time, mode of operation (continuous or pulsed), etc.
- Avoid exposure of eyes and skin to radiation.
 - Do not introduce reflective objects into the beam path.
 - Never remove covers or cover panels during operation.
 - Do not disable any interlock system elements.
 - Use suitable protective equipment / protective clothing if required.
- Electromagnetic Radiation Hazards** The microscope may cause radio interference, which may be mitigated by relocating or re-orienting the equipment. The use of non-specified accessories, cables, or other auxiliary parts from the field of information technology may lead to increased electromagnetic emissions and reduced immunity to interference. Any integration into the system may result in a degradation of the EMC performance.

2.3.7 Thermal Hazards

- Burning Hazards** Hot surfaces, radiation and/or aggressive chemicals can cause burns.
- Use suitable protective equipment / protective clothing if mandatory.
 - Always observe the cooling time of the hot surfaces.

- Heat Accumulation** Covering the ventilation openings can lead to heat accumulation that may damage the microscope and its components and, in extreme cases, can cause a fire.
- Keep ventilation openings unobstructed at all times.
 - Do not cover devices or openings emitting heat.
 - Do not obstruct ventilation.
 - Comply with minimum distance from walls.

2.4 Labels and Lights

This chapter shows labels and, where applicable, indicator lights. All parts that may pose specific hazards are marked with warning labels. Always observe **all** warning labels!

- Check all warning labels for availability and legibility.
- Immediately replace damaged or illegible warning labels.

In case a label is missing please contact your ZEISS service representative for free of charge replacement.

2.4.1 Labels on the Axiolab 5

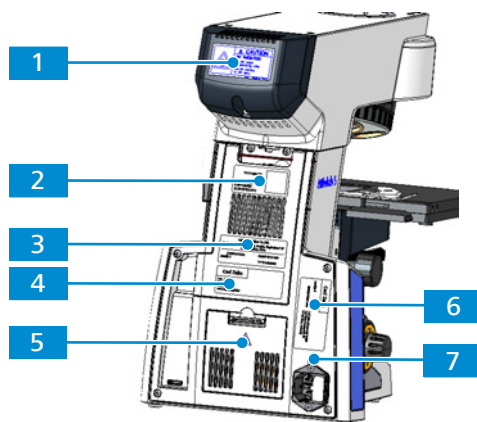

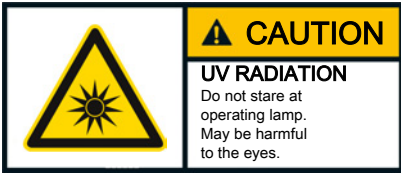

Fig. 1: Position of warning labels Axiolab 5 for transmitted light and reflected light

Pos.	Label or light	Explanation
1		CAUTION LED Radiation Do not stare at operating lamp. May be harmful to the eyes.
Only for reflected light.		Only valid when the 385 nm LED is used: CAUTION UV Radiation Do not stare at operating lamp. May be harmful to the eyes.

Pos.	Label or light	Explanation
2		UDI label
3		Microscope type label
4		Microscope type label not applicable for Axiolab 5 materials microscopes
		Microscope type label only applicable for Axiolab 5 materials microscopes
5		Hot surface! Do not touch.
6		Axiolab 5, Axiolab 5 materials EU Representative Carl Zeiss Microscopy GmbH Carl-Zeiss-Promenade 10 07745 Jena, Germany
7		Observe the safety notes in the instruction manual and the supplied documents.

2.5 Safety Devices and Interlocks

In order to prevent injuries and/or property damage, the microscope is equipped with several safety devices and interlocks. In case of defect or damage, the affected parts and the microscope must be taken out of operation immediately and must be secured against unintentional use.

To verify the safety of the microscope, contact your ZEISS service representative and keep the service logs and logbooks.

3 Product and Functional Description

The Axiolab 5, Axiolab 5 materials is a transmitted-light microscope of compact design with a small footprint. The microscope provides high resolution, infinity-corrected objectives for transmitted-light techniques and for reflected-light techniques, depending on the microscope type.

Depending on the configuration of the microscope, the following microscopy and contrast techniques are available:

- Transmitted light (TL)**
 - *Brightfield (BF)* [[▶ 40](#)]
 - *Darkfield (DF)* [[▶ 40](#)]
 - *Phase contrast (Ph)* [[▶ 40](#)]
 - *Polarization (Pol)* [[▶ 41](#)]
 - *Polarization (Conoscopy)* [[▶ 45](#)]
- Reflected light (RL)**
 - *Brightfield (BF)* [[▶ 45](#)]
 - *Darkfield (DF)* [[▶ 46](#)]
 - *Polarization (Pol)* [[▶ 46](#)]
 - *Fluorescence (FL)* [[▶ 46](#)]

The following microscope types are available:

Axiolab 5 Bio-TL	Transmitted light stand for bioscience
Axiolab 5 Bio-TL/FL	Transmitted light and reflected light fluorescence stand for bioscience
Axiolab 5 Pol-TL	Transmitted light stand for polarization
Axiolab 5 Pol-TL/ conoscopy	Transmitted light stand for polarization/conoscopy
Axiolab 5 Pol-TL/RL	Transmitted light and reflected light stand for polarization
Axiolab 5 Mat-TL/RL	Transmitted light and reflected light materials stand

Typical Applications

- Axiolab 5
- examination of blood and tissue samples taken from the human body, from plants, or animals
 - medical examinations in laboratories, hospitals, and doctors' offices
 - academic and practical education in medicine and biology
 - industrial applications, e.g. in pharmacology, food technology, and wastewater examination

Axiolab 5 materials

- metallographic laboratories
- automotive industry
- microsystems engineering
- geoscientific institutes
- mineral exploration industry

Info

Additional information about the hardware configuration and optional enhancements can be obtained from your ZEISS Sales & Service Partner.

3.1 Main Components

3.1.1 Axiolab 5 Bio-TL

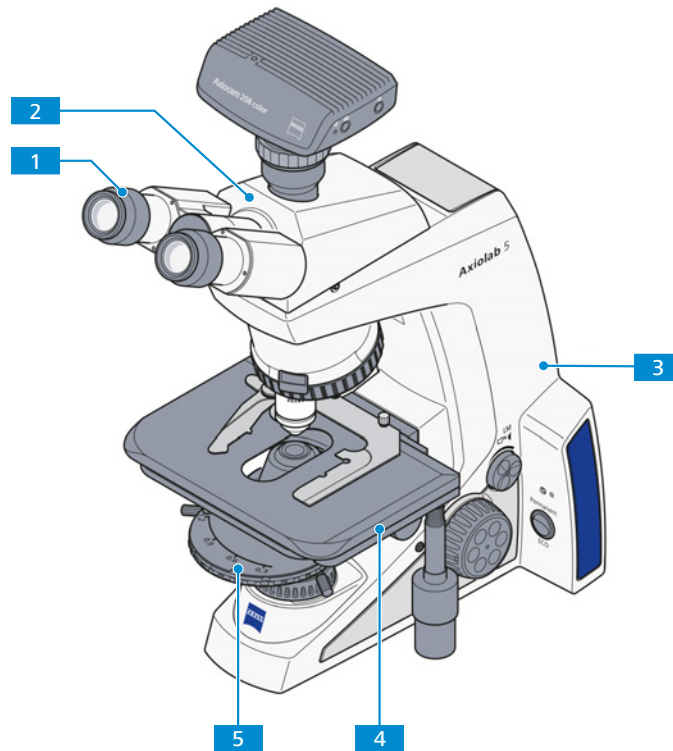

Fig. 2: Main components - Axiolab 5 Bio-TL

- | | |
|---|--|
| 1 Eyepieces [▶ 34] | 2 Binocular tube [▶ 31] |
| 3 Stand Bio/TL | 4 Mechanical stage [▶ 37] |
| 5 Condenser [▶ 36] | |

3.1.2 Axiolab 5 Bio-TL/FL

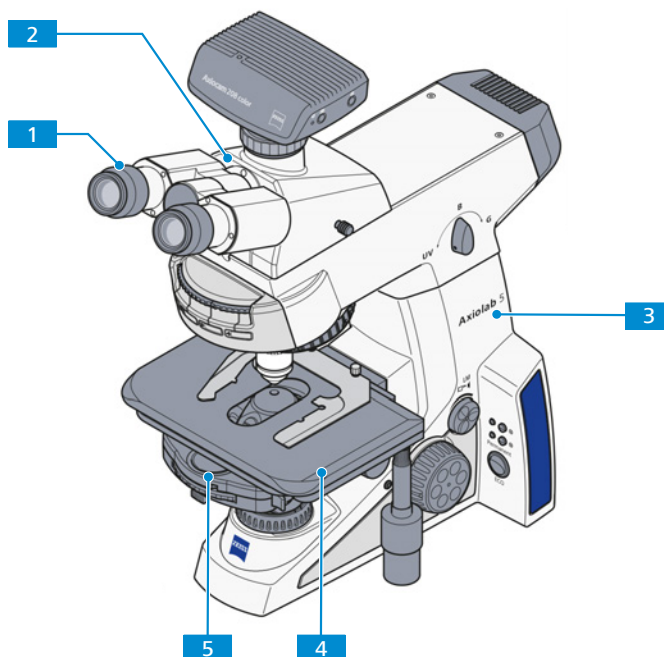

Fig. 3: Main components - Axiolab 5 Bio-TL/FL

- | | |
|---|--|
| 1 Eyepieces [▶ 34] | 2 Binocular tube [▶ 31] |
| 3 Stand Bio-TL/FL | 4 Mechanical stage [▶ 37] |
| 5 Condenser [▶ 36] | |

3.1.3 Axiolab 5 Pol-TL

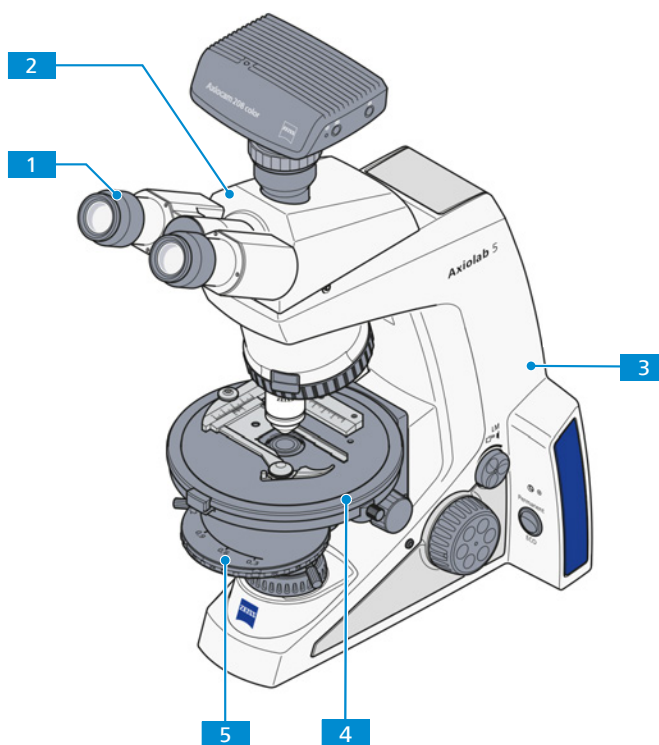

Fig. 4: Main components - Axiolab 5 Pol-TL

- | | |
|---|--|
| 1 Eyepieces [▶ 34] | 2 Binocular tube [▶ 31] |
| 3 Stand Pol-TL | 4 Rotary stage [▶ 37] |
| 5 Condenser [▶ 36] | |

3.1.4 Axiolab 5 Pol-TL/conoscopy

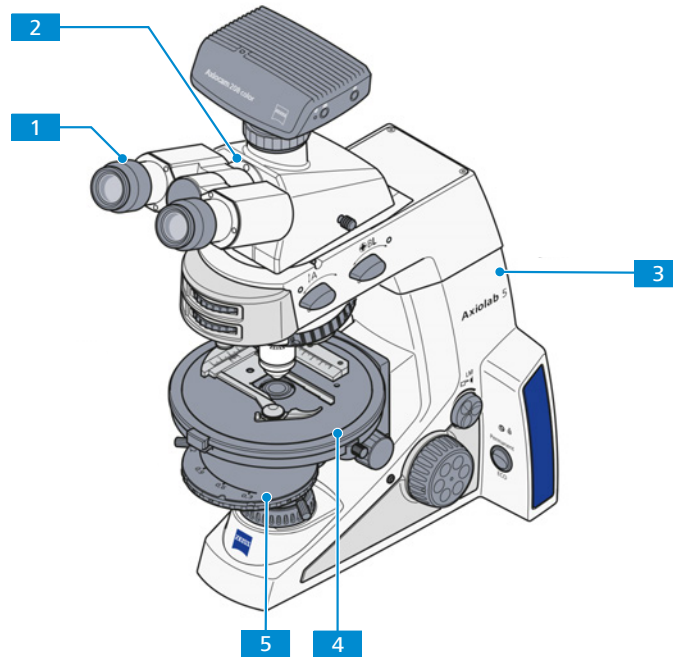

Fig. 5: Main components - Axiolab 5 Pol-TL/conoscopy

- | | |
|---------------------------------|--------------------------------|
| 1 Eyepieces [▶ 34] | 2 Binocular tube [▶ 31] |
| 3 Stand Pol-TL/conoscopy | 4 Rotary stage [▶ 37] |
| 5 Condenser [▶ 36] | |

3.1.5 Axiolab 5 Pol-TL/RL

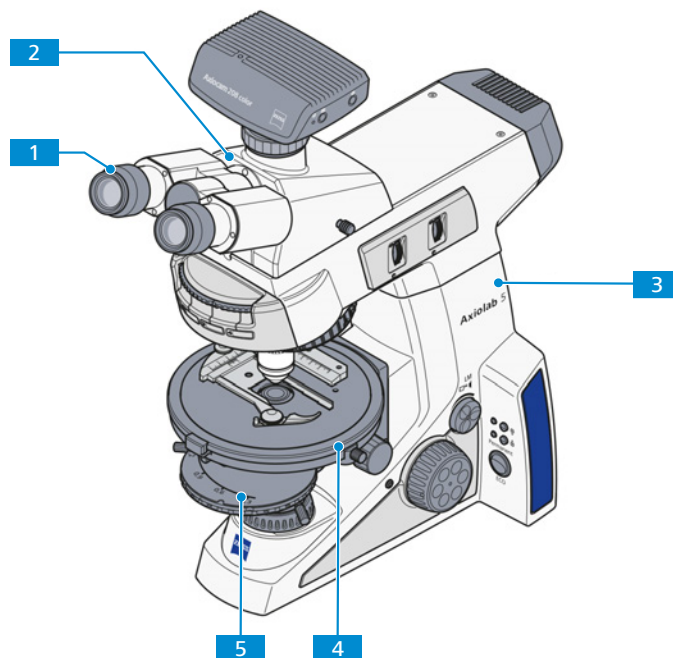

Fig. 6: Main components - Axiolab 5 Pol-TL/RL

- | | |
|---------------------------|--------------------------------|
| 1 Eyepieces [▶ 34] | 2 Binocular tube [▶ 31] |
| 3 Stand Pol-TL/RL | 4 Rotary stage [▶ 37] |
| 5 Condenser [▶ 36] | |

3.1.6 Axiolab 5 Mat-TL/RL

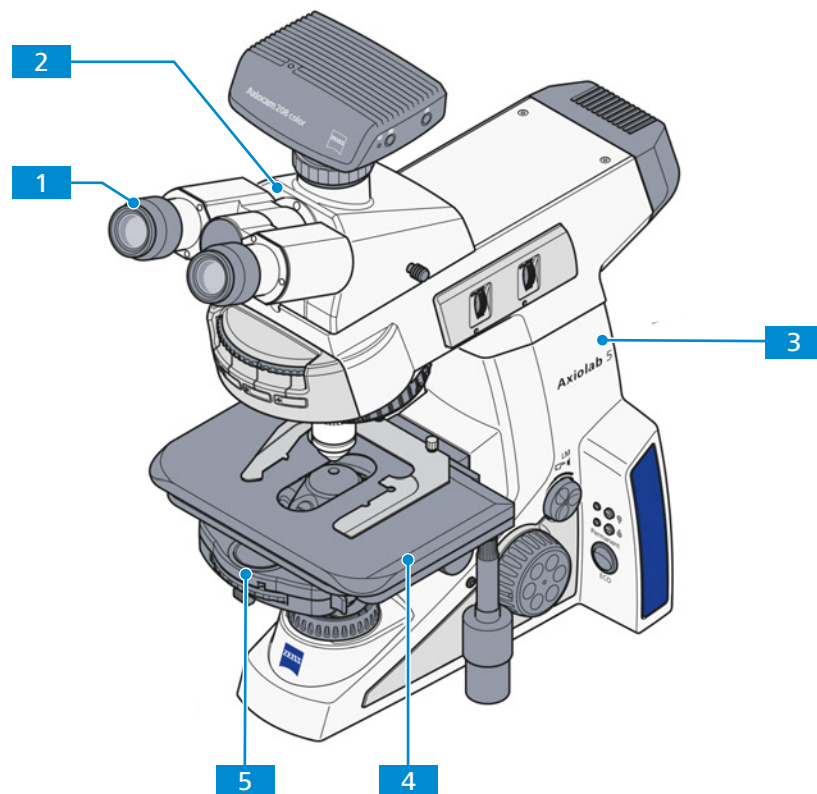

Fig. 7: Main component - Axiolab 5 Mat-TL/RL

- | | | | |
|----------|-------------------------|----------|--------------------------------|
| 1 | <i>Eyepieces [▶ 34]</i> | 2 | <i>Binocular tube [▶ 31]</i> |
| 3 | <i>Stand Mat-TL/RL</i> | 4 | <i>Mechanical stage [▶ 37]</i> |
| 5 | <i>Condenser [▶ 36]</i> | | |

3.2 Controls and Functional Elements on Components

3.2.1 Axiolab 5 Bio-TL Stand

This section shows the functional components and controls of stand Bio-TL.

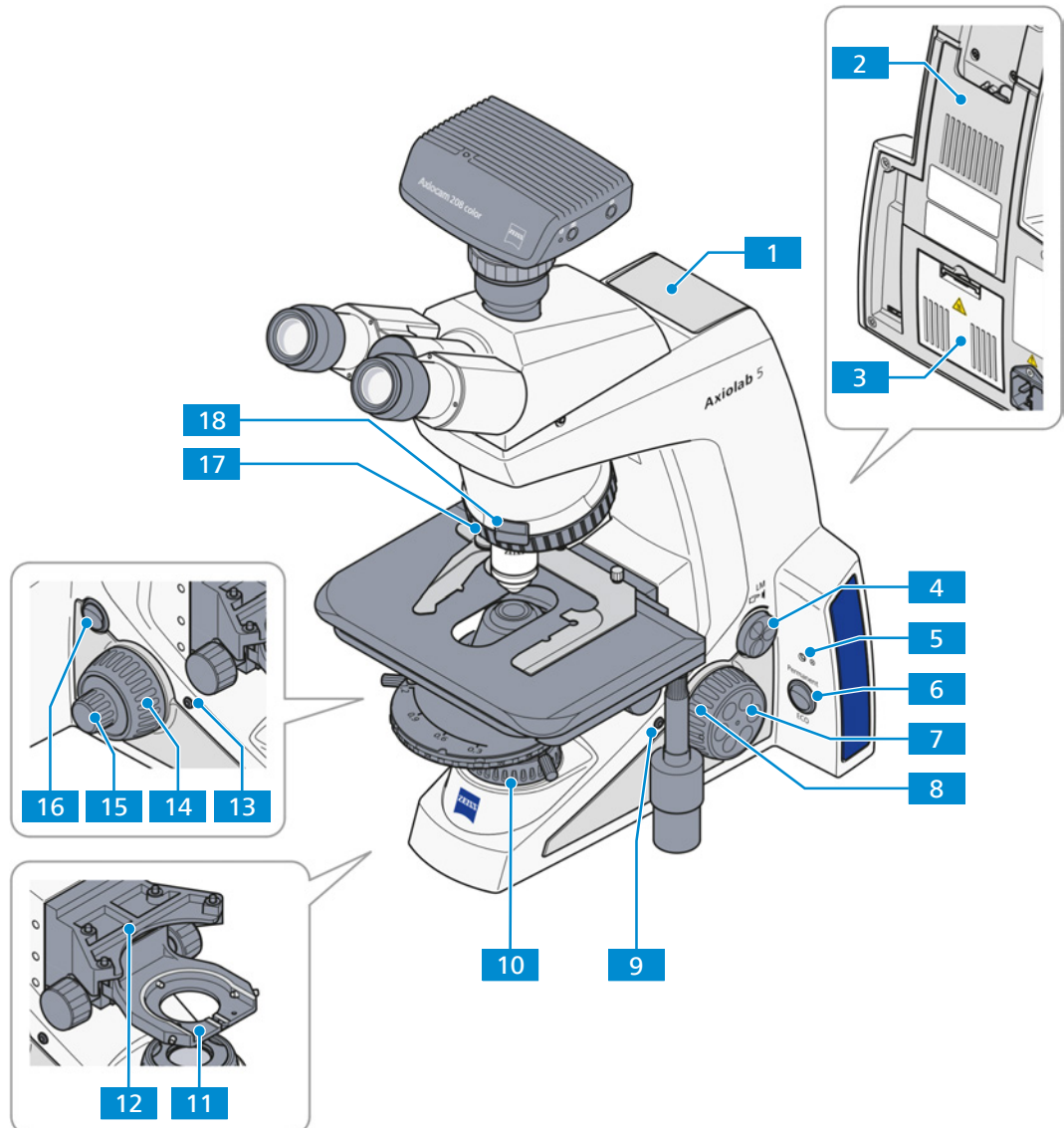

Fig. 8: Functional components and controls - stand Bio-TL

- | | |
|--|--|
| 1 Carrying handle | 2 Tool kit storage/cable holder |
| 3 Transmitted light light source (inside) | 4 Intensity/LM knob |
| 5 Indicator light | 6 Permanent/ECO mode switch |
| 7 Focusing drive – fine adjustment (right side, finger wheel) | 8 Focusing drive – coarse adjustment (right side) |
| 9 Snap button (right side) | 10 Luminous-field diaphragm |
| 11 <i>Condenser carrier</i> [▶ 35] | 12 Stage carrier for mechanical stages |
| 13 Snap button (left side) | 14 Focusing drive – coarse adjustment (left side) |
| 15 Focusing drive – fine adjustment (left side) | 16 Power switch On/Off |
| 17 <i>Nosepiece</i> [▶ 35] with 5 positions BF | 18 Slot for 6x20mm slider |

3.2.2 Axiolab 5 Bio-TL/FL Stand

This section shows the functional elements and controls of stand Bio-TL/FL.

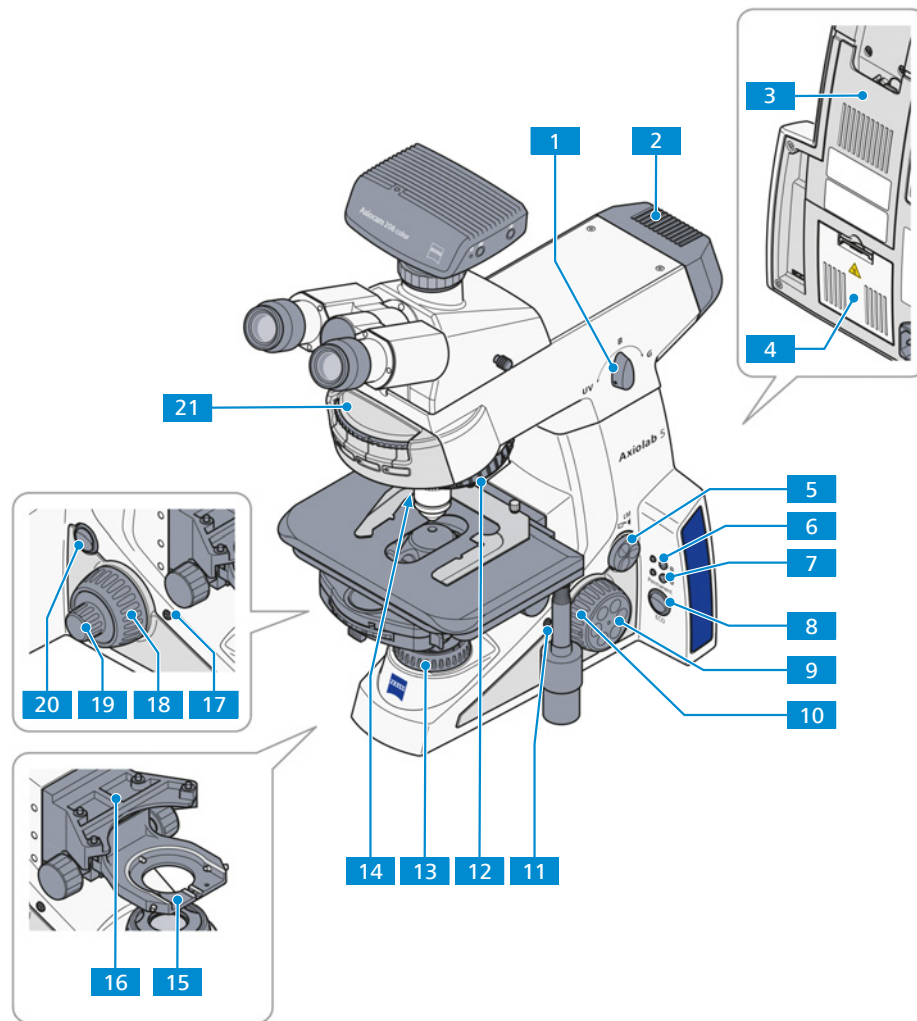

Fig. 9: Functional components and controls - stand Bio-TL/FL

- | | |
|--|--|
| 1 LED selection knob for 3 positions (UV, B, G) | 2 FL-LED reflected light light source |
| 3 Tool kit storage/cable holder | 4 Transmitted light light source (inside) |
| 5 Intensity/LM knob | 6 Reflected light (RL) button and indicator light for reflected light |
| 7 Transmitted light (TL) button and indicator light for transmitted light | 8 Permanent/ECO mode switch |
| 9 Focusing drive – fine adjustment (right side, finger wheel) | 10 Focusing drive – coarse adjustment (right side) |
| 11 Snap button (right side) | 12 Nosepiece with 5 positions BF |
| 13 Luminous-field diaphragm | 14 Slot for 6x20mm slider |
| 15 Condenser carrier | 16 Stage carrier for mechanical stages |
| 17 Snap button (left side) | 18 Focusing drive – coarse adjustment (left side) |
| 19 Focusing drive – fine adjustment (left side) | 20 Power switch On/Off |
| 21 4-position reflector turret | |

3.2.3 Axiolab 5 Pol-TL Stand

This section shows the functional elements and controls of stand Pol-TL.

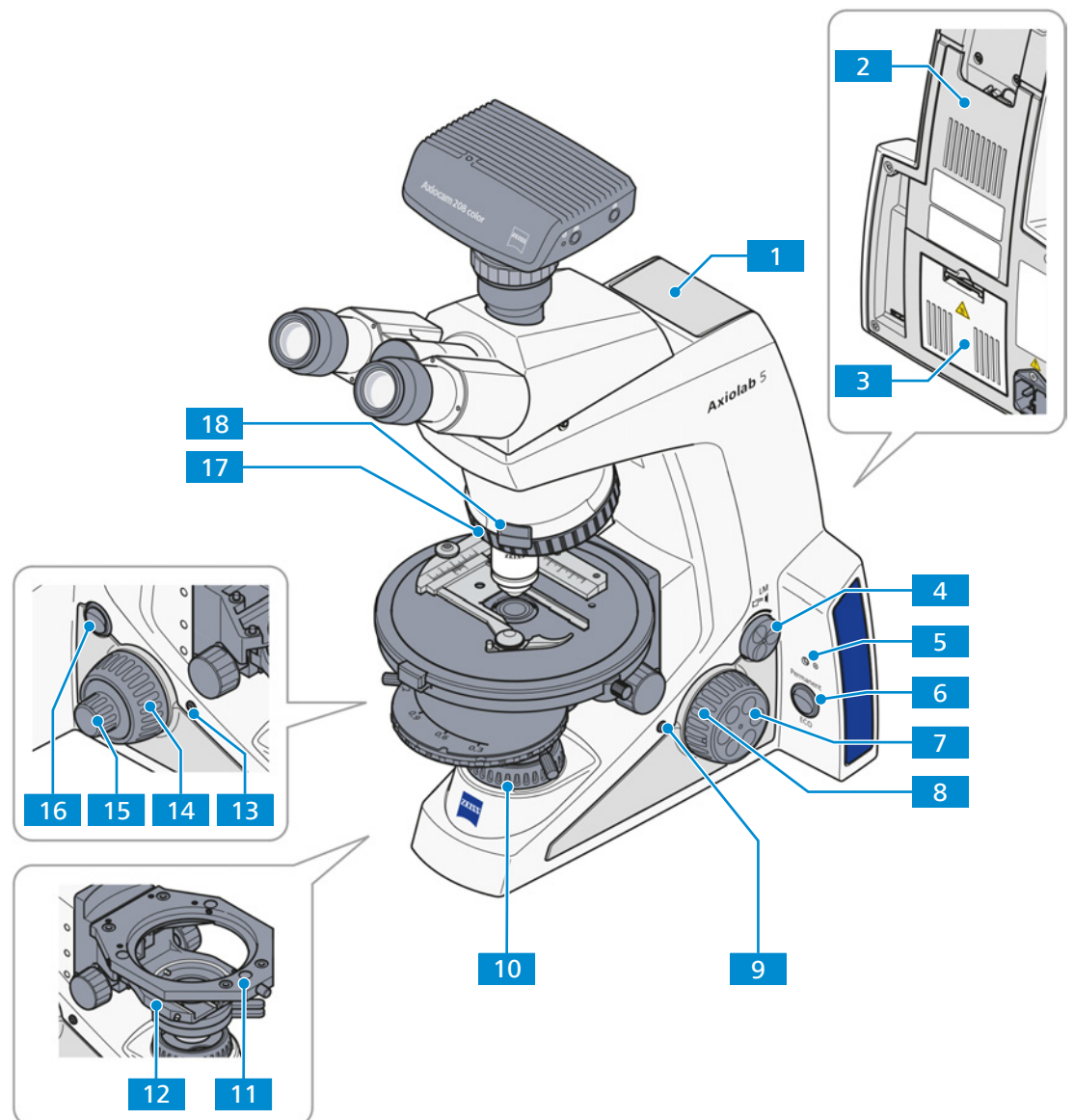

Fig. 10: Functional components and controls - stand Pol-TL

- | | |
|--|--|
| 1 Carrying handle | 2 Tool kit storage/cable holder |
| 3 Transmitted light light source (inside) | 4 Intensity/LM knob |
| 5 Indicator light | 6 Permanent/ECO mode switch |
| 7 Focusing drive – fine adjustment (right side, finger wheel) | 8 Focusing drive – coarse adjustment (right side) |
| 9 Snap button (right side) | 10 Luminous-field diaphragm |
| 11 Stage carrier for rotary stages | 12 Condenser carrier with mounted polarizer |
| 13 Snap button (left side) | 14 Focusing drive – coarse adjustment (left side) |
| 15 Focusing drive – fine adjustment (left side) | 16 Power switch On/Off |
| 17 Nosepiece with 5 positions BF | 18 Slot for 6x20mm slider |

3.2.4 Axiolab 5 Pol-TL/conoscopy Stand

This section shows the functional elements and controls of stand Pol-TL/conoscopy.

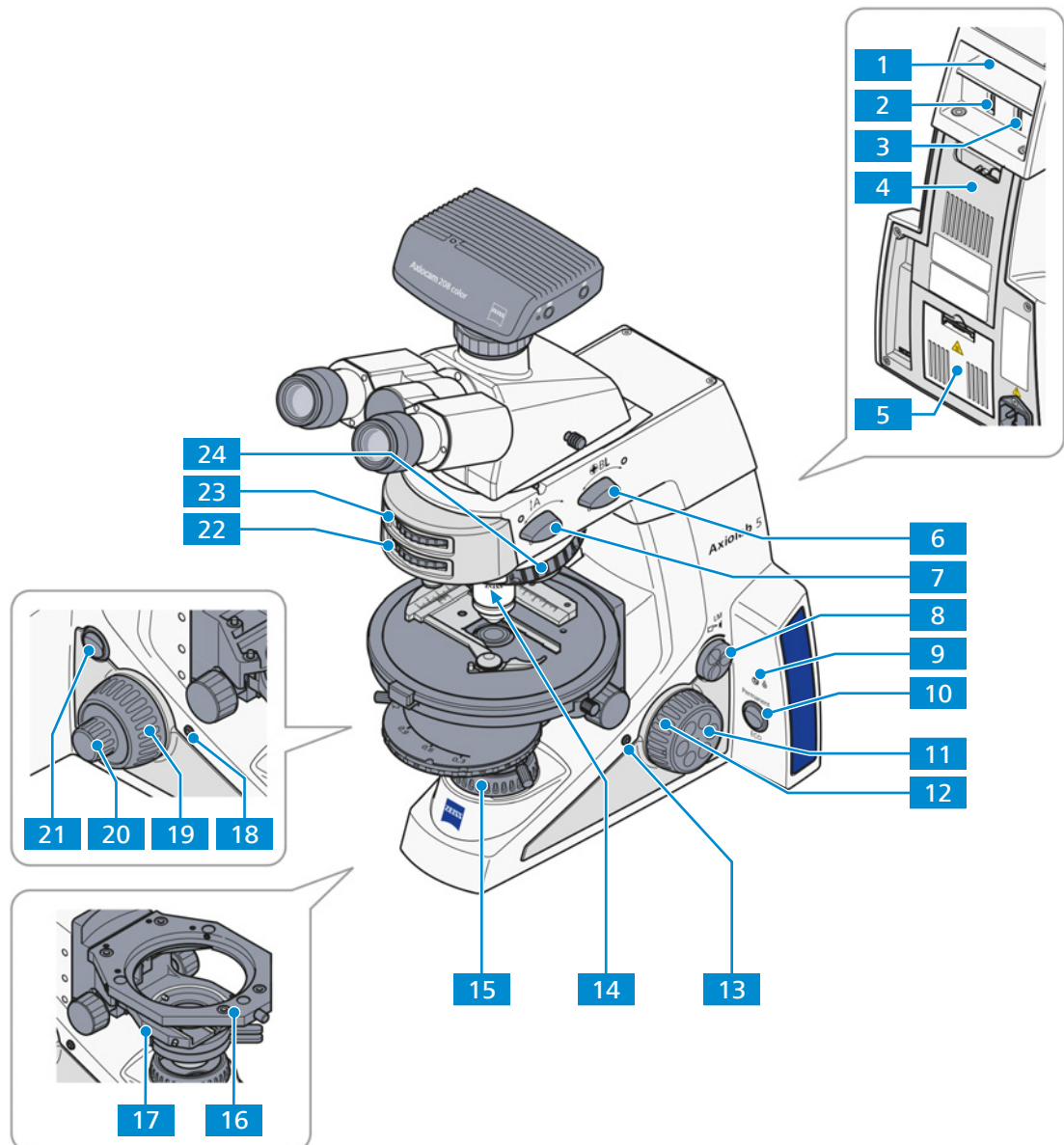

Fig. 11: Functional elements and controls - stand Pol-TL/conoscopy

- | | |
|---|---|
| 1 Carrying handle | 2 Storage compartment for one 6x20mm slider |
| 3 Storage compartment for one 6x20mm slider | 4 Tool kit storage/cable holder |
| 5 Transmitted light light source (inside) | 6 Rotary knob BL |
| 7 Rotary knob A | 8 Intensity/LM knob |
| 9 Indicator light | 10 Permanent/ECO mode switch |
| 11 Focusing drive – fine adjustment (right side, finger wheel) | 12 Focusing drive – coarse adjustment (right side) |
| 13 Snap button (right side) | 14 Slot for 6x20mm slider |
| 15 Luminous-field diaphragm | 16 Stage carrier for rotary stages (also suitable for mechanical stages) |

- 17** Condenser carrier with mounted polarizer
- 18** Snap button(left side)
- 19** Focusing drive – coarse adjustment (left side)
- 20** Focusing drive – fine adjustment (left side)
- 21** Power switch On/Off
- 22** Setting wheel for polarization direction of analyzer
- 23** Setting wheel for focusing of Bertrand lens
- 24** Nosepiece with 5 positions BF Pol (with 4x centerable, 1x fixed)

3.2.5 Axiolab 5 Pol-TL/RL Stand

This section shows the functional elements and controls of stand Pol-TL/RL.

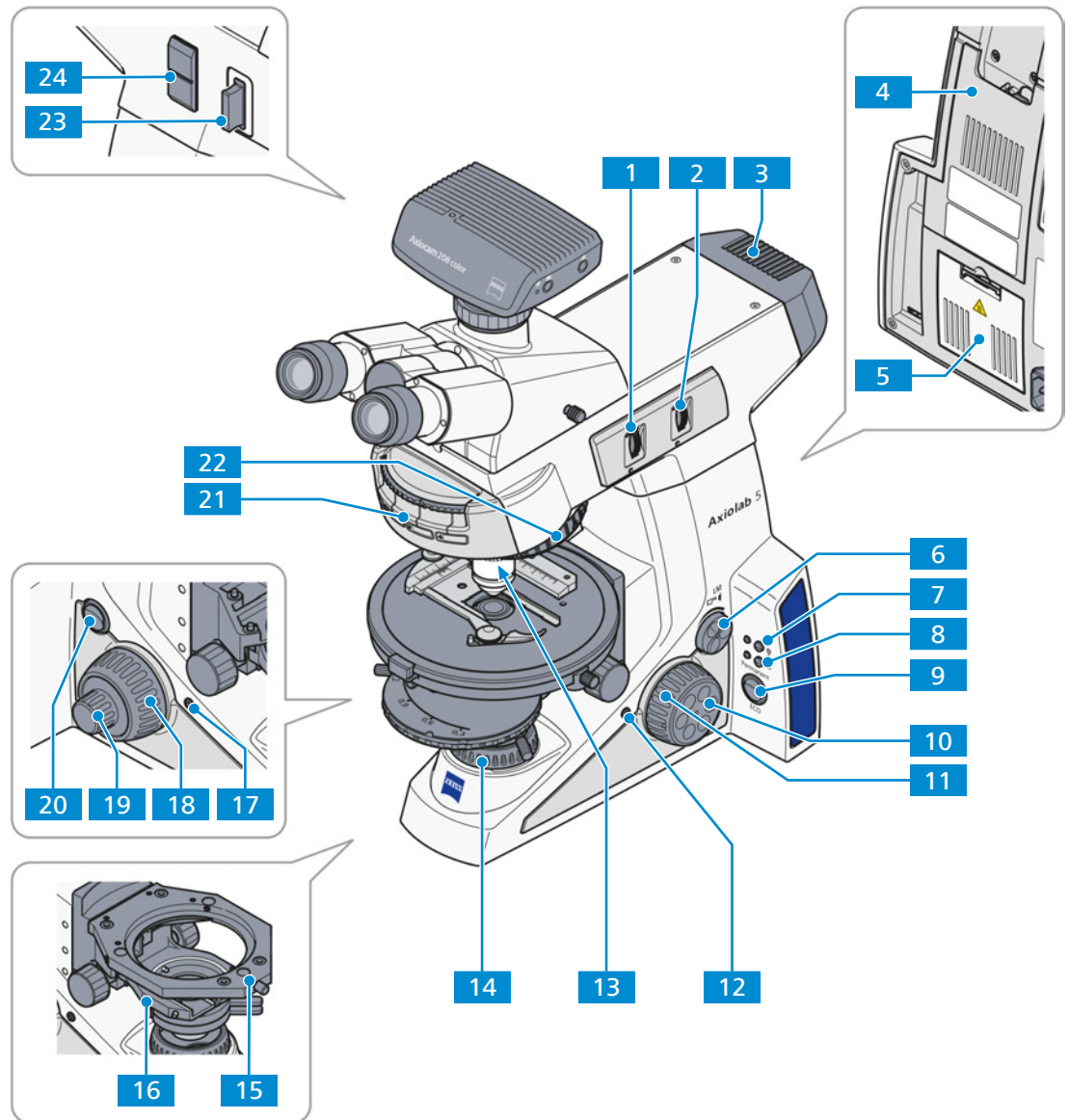

Fig. 12: Functional elements and controls - stand Pol-TL/RL

- 1** Luminous-field diaphragm for reflected light (centered)
- 2** Aperture diaphragm for reflected light (centered)
- 3** Reflected light light source
- 4** Tool kit storage/cable holder
- 5** Transmitted light light source (inside)
- 6** Intensity/LM knob

- 7** **Reflected light (RL) button** and indicator light for reflected light
- 9** **Permanent/ECO mode switch**
- 11** Focusing drive – coarse adjustment (right side)
- 13** Slot for 6x20mm slider
- 15** Stage carrier for rotary stages (also suitable for mechanical stages)
- 17** **Snap button** (left side)
- 19** Focusing drive – fine adjustment (left side)
- 21** 4-position reflector turret
- 23** Slot for polarizer slider 6x30mm, reflected light (slider inserted)
- 8** **Transmitted light (TL) button** and indicator light for transmitted light
- 10** Focusing drive – fine adjustment (right side, finger wheel)
- 12** **Snap button** (right side)
- 14** Luminous-field diaphragm
- 16** Condenser carrier with mounted polarizer
- 18** Focusing drive – coarse adjustment (left side)
- 20** **Power switch On/Off**
- 22** Nosepiece, with 5 positions BF DF Pol
- 24** Slot for 2-position filter slider, reflected light (covered)

3.2.6 Axiolab 5 Mat-TL/RL Stand

This section shows the functional elements and controls of stand Mat-TL/RL.

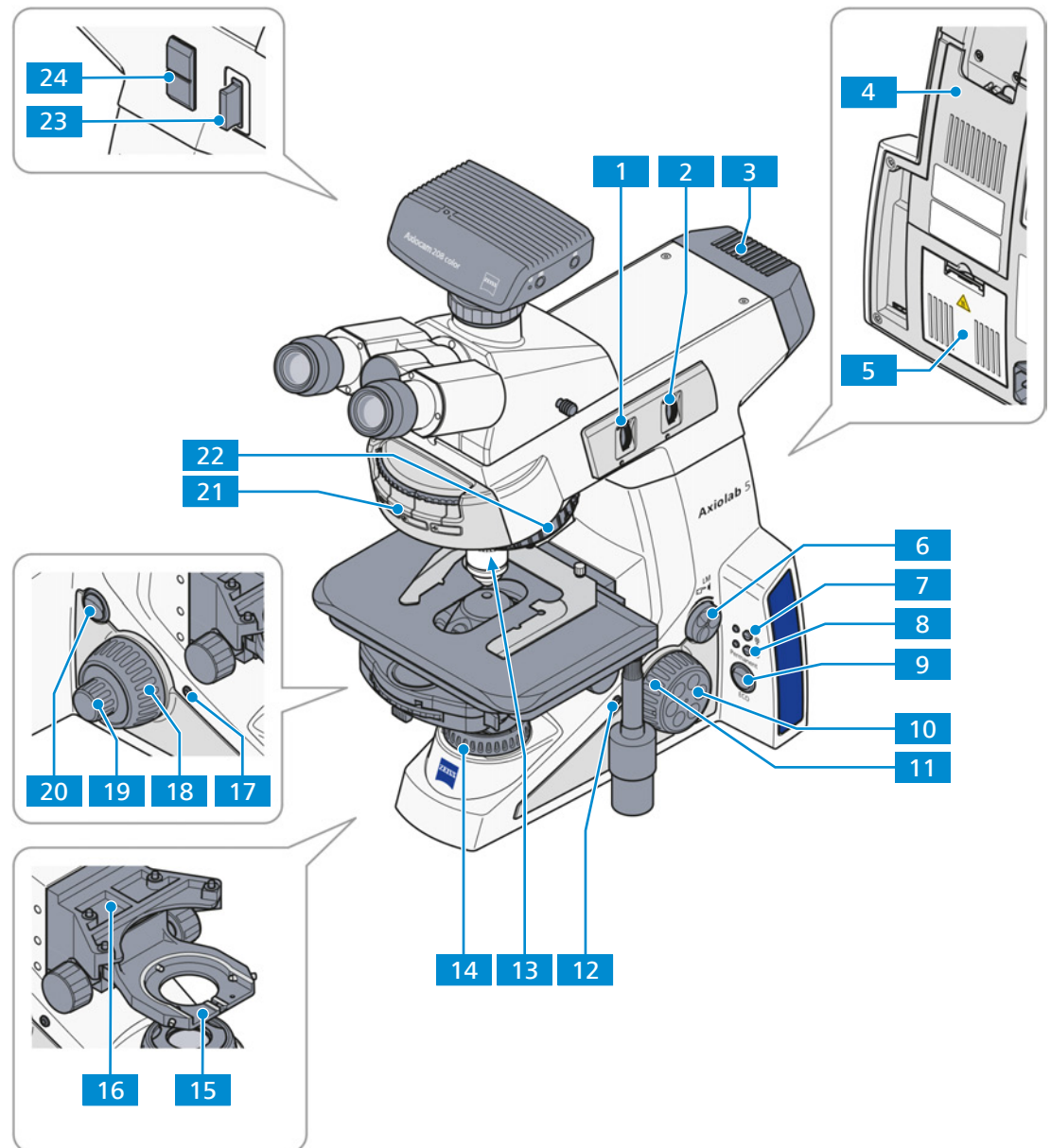

Fig. 13: Functional elements and controls - stand Mat-TL/RL

- | | |
|---|---|
| 1 Luminous-field diaphragm for reflected light (centered) | 2 Aperture diaphragm for reflected light (centered) |
| 3 Reflected light light source | 4 Tool kit storage/cable holder |
| 5 Transmitted light light source (inside) | 6 Intensity/LM knob |
| 7 Reflected light (RL) button and indicator light for reflected light | 8 Transmitted light (TL) button and indicator light for transmitted light |
| 9 Permanent/ECO mode switch | 10 Focusing drive – fine adjustment (right side, finger wheel) |
| 11 Focusing drive – coarse adjustment (right side) | 12 Snap button (right side) |
| 13 Slot for 6x20mm slider | 14 Luminous-field diaphragm |

- | | |
|--|--|
| <p>15 Condenser carrier</p> <p>17 Snap button (left side)</p> <p>19 Focusing drive – fine adjustment (left side)</p> <p>21 4-position reflector turret</p> <p>23 Slot for polarizer slider 6x30mm, reflected light (slider inserted)</p> | <p>16 Stage carrier for mechanical stages</p> <p>18 Focusing drive – coarse adjustment (left side)</p> <p>20 Power switch On/Off</p> <p>22 Nosepiece, with 5 positions BF DF</p> <p>24 Slot for filter slider, reflected light (covered)</p> |
|--|--|

3.2.7 Functions of Stand Keys and Display Elements

Key	Action	Functionality/Description
Power switch On/Off	I = on; O = off	Switches the microscope on/off
Permanent/ECO mode switch	Toggle	<p>Switches between Permanent (continuous) mode and ECO mode of the microscope illumination.</p> <ul style="list-style-type: none"> ▪ Permanent mode active: illumination is continuously switched on. ▪ ECO mode active: illumination switches off after 15 minutes without action. <p>Don't use ECO mode for experiments involving time-lapse or video recording.</p>
Indicator light	Blinking***	Indicates whether microscope is working in TL or RL mode.
RL button, TL button	Short press*	<p>Switches RL/TL illumination alternately on/off.</p> <p>The respective indicator light is continuously illuminated.</p>
Intensity/LM knob	Turn	Controls the light intensity of the active light source.
	Long press**	<p>Light Manager function:</p> <p>Saves the light intensity; after saving is done, the illumination switches off for 300 ms (darkness indicates action to user).</p>
	Long press for 20 s	<p>Activates the factory default settings (enables/disables Light Manager (LM) functionality).</p> <p>The indicator light starts blinking in RED after 3 s until 20 s is reached. After 20 s, the indicator light turns to GREEN continuously.</p>

Key	Action	Functionality/Description
Left Snap button or right Snap button (only if Axiocam 202 or 208 is installed)	Short press*	Snaps an image; after snap is finished, the attached monitor appears in BLACK for 50 ms.
	Long press**	Starts video recording; another short press is required to stop recording. After recording is finished, the attached monitor appears in BLACK for 300 ms.
Snap button + Intensity/LM knob	Long press** (simultaneously)	Enables/disables the Light Manager (LM) functionality: <ul style="list-style-type: none"> Disabling: The indicator light blinks GREEN / ORANGE / GREEN in sequence. Enabling: The indicator light blinks GREEN / GREEN / GREEN in sequence.

* Short press means: hold less than 1 second, then release.

** Long press means: hold at least 1.5 seconds.

*** Blinking: the indicator light alternately goes on/off at 500 ms intervals

3.2.8 Binocular Tubes

3.2.8.1 Binocular Photo Tube 30°/23 (50:50)

Purpose Binocular photo tubes are used to visualize the microscopic image by means of the eyepieces. Using the camera port, the microscopic image can be sent to a connected camera.

Position The binocular photo tubes are mounted on the top of the stand.

Function The pupil distance and the viewing height can be adjusted with the aid of the binocular section. The following features and controls are available:

- reversed image
- camera port with fixed light graduation (50:50)
- viewing angle 30°
- field of view 23 mm

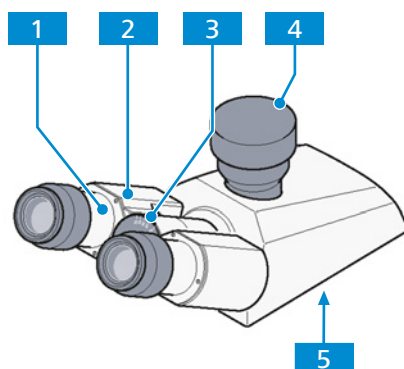

Fig. 14: Binocular Photo Tube 30°/23 (50:50)

1 Eyepiece socket

3 Angle scale

5 Dovetail ring mount

2 Binocular section

4 Camera port (covered)

3.2.8.2 Binocular Photo Tube 30°/23 (100:0/0:100)

Purpose Binocular photo tubes are used to visualize the microscopic image by means of the eyepieces. Using the camera port, the microscopic image can be sent to a connected camera.

Position The binocular photo tubes are mounted on the top of the stand.

Function The pupil distance and the viewing height can be adjusted with the aid of the binocular section. The following features and controls are available:

- reversed image
- camera port with toggle graduation (100:0/0:100)
- viewing angle 30°
- eyepiece shutter
- field of view 23 mm

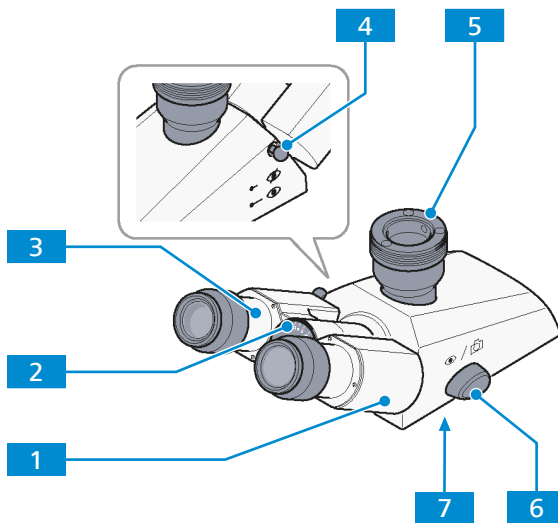

Fig. 15: Binocular Photo Tube 30°/23 (100:0/0:100)

- | | |
|---|--|
| <p>1 Binocular section</p> <p>3 Eyepiece socket</p> <p>5 Camera port</p> <p>7 Dovetail ring mount</p> | <p>2 Angle scale</p> <p>4 Eyepiece shutter</p> <ul style="list-style-type: none"> ▪ Push-pull rod pushed in: eyepiece shutter closed ▪ Push-pull rod pulled out: eyepiece shutter opened <p>6 Shift knob for selecting the graduation</p> <ul style="list-style-type: none"> ▪ Shift knob to front (eye symbol): 100% light to eyepieces ▪ Shift knob to the rear (camera symbol): 100% light to camera |
|---|--|

3.2.8.3 Binocular Photo Tube 20°/23 (100:0/0:100)

Purpose Binocular photo tubes are used to visualize the microscopic image by means of the eyepieces. Using the camera port, the microscopic image can be sent to a connected camera.

Position The binocular photo tubes are mounted on the top of the stand.

Function The pupil distance and the viewing height can be adjusted with the aid of the binocular section. The following features and controls are available:

- upright image
- camera port with toggle graduation (100:0/0:100)
- viewing angle 20°
- field of view 23 mm

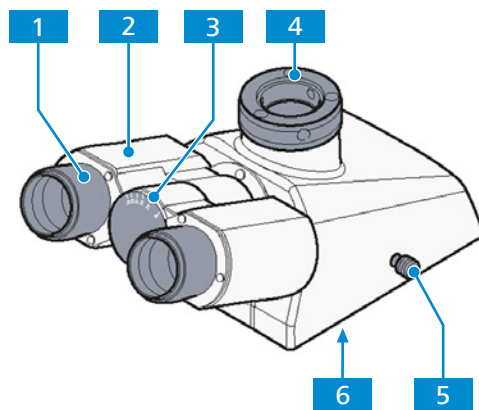

Fig. 16: Binocular Photo Tube 20°/23 (100:0/0:100)

- | | | | |
|----------|-------------------------------------|----------|---------------------|
| 1 | Eyepiece socket | 2 | Binocular section |
| 3 | Angle scale | 4 | Camera port |
| 5 | Slider for selecting the graduation | 6 | Dovetail ring mount |
- Slider pushed in: 100% light to eye-pieces
 - Slider pulled out: 100% light to camera. 100% light to camera

3.2.9 Eyepieces

- Purpose** The eyepieces serve to observe the microscopic image.
- Position** The eyepieces are inserted into the tube.
- Function** Both eyepieces are suitable for spectacle wearers. Additionally, they contain a focusing ring for compensation of defective vision. The provided diopter scale helps to find the correct setting. When using the microscope for fluorescence applications, the special eyecups with light protection can be used. However, they cannot be folded over and are not suitable for spectacle wearers.

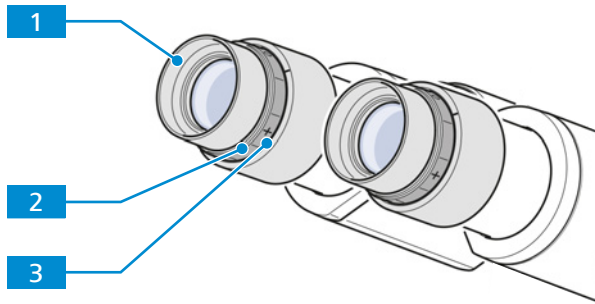

Fig. 17: Eyepiece

- 1** Eyecup, changeable
- 2** Focusing ring for compensation of defective vision
- 3** Diopter scale to facilitate finding the correct setting

3.2.10 Eyepieces with Eyepiece Reticles

- Purpose** The eyepieces with eyepiece reticles serve to observe the microscopic image in special microscopy procedures.
- Position** The eyepieces with reticles are inserted into the tube.
The eyepiece reticles must be inserted under dust-free conditions. This should be carried out only by ZEISS Service.

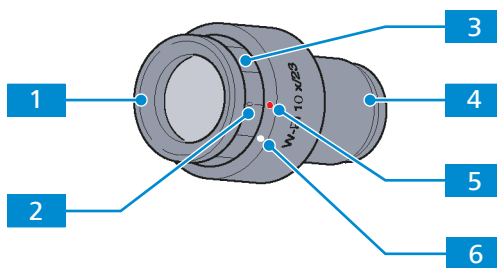

Fig. 18: Eyepiece with installed eyepiece reticle

- 1** Eyecup, changeable
- 2** Diopter scale with zero point to facilitate finding the correct setting
- 3** Focusing ring for compensation of defective vision
- 4** Mounting stop with inserted eyepiece reticle
- 5** Red dot, corresponds to the zero diopter setting when a reticle is inserted
- 6** White dot, corresponds to the zero diopter setting when no reticle is inserted

3.2.11 Nosepiece with Objectives

Purpose The nosepiece is used to hold the objectives and to swivel the desired objective into the beam path.

Position The nosepiece is mounted on the upper part of the stand.

The following features and controls are available:

- nosepiece with M27 mounting thread for five objectives
- one objective position is fixed and four positions can be centered with the aid of two screws each
- equipped with slot for 6x20mm sliders (compensators, analyzers, quarter plates or fluorescence protection shield)

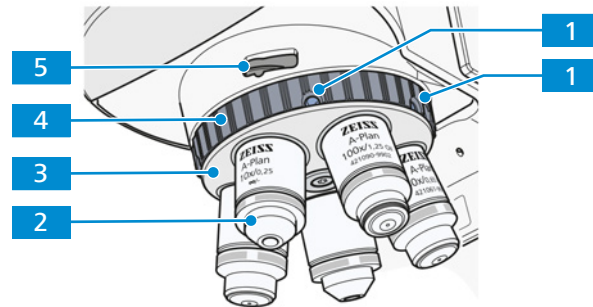

Fig. 19: Nosepiece with objectives

- | | | | |
|----------|--|----------|--|
| 1 | Centering screw, two for each center-able objective position | 2 | Objective |
| 3 | Nosepiece | 4 | Knurled ring for swivelling the nose-piece |
| 5 | Slot 6x20mm | | |

3.2.12 Condenser Carrier

Purpose The condenser carrier is used to hold the condenser.

Position The condenser carrier is mounted onto the stage carrier.

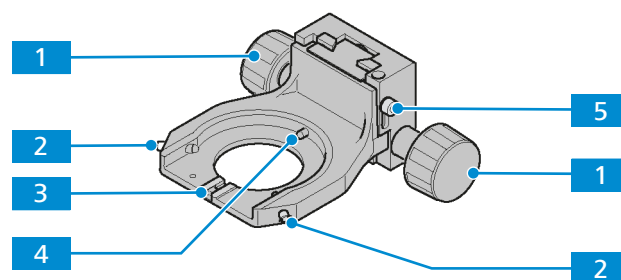

Fig. 20: Condenser carrier

- | | | | |
|----------|---|----------|---|
| 1 | Knurled knob for vertical adjustment (left/right) | 2 | Centering hex screw (left/right), optional: knurled screw |
| 3 | Orientation groove | 4 | Main spring |
| 5 | Fastening screw for height stop | | |

3.2.13 Condensers

3.2.13.1 Condenser 0.9/1.25 BF

Purpose Condensers are used to optimize the transmitted light illumination. The condenser 0.9/1.25 BF is usable for brightfield applications.

Position The condenser is mounted on the condenser carrier of the stand.

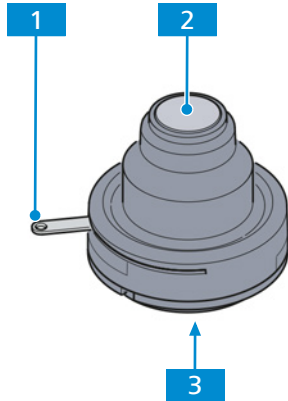

Fig. 21: Condenser 0.9/1.25 BF

- | | | | |
|----------|--|----------|------------|
| 1 | Lever for setting the aperture diaphragm | 2 | Front lens |
| 3 | Dovetail ring mount | | |

3.2.13.2 Condenser 0.9/1.25 BF, DF, Ph1, Ph2, Ph3 with modulator disk

Purpose Condensers are used to optimize the transmitted light illumination. The condenser with modulator disk is usable for brightfield, darkfield and phase contrast applications.

Position The condenser is mounted on the condenser carrier of the stand.

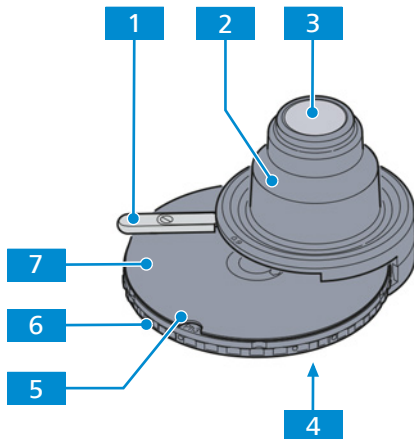

Fig. 22: Condenser 0.9/1.25 BF, DF, Ph1, Ph2, Ph3 with modulator disk

- | | | | |
|----------|---|----------|---|
| 1 | Lever for setting the aperture diaphragm | 2 | Front lens |
| 3 | Condenser 0.9/1.25 BF, optionally condenser 0.9/1.25 BF Pol | 4 | Dovetail ring mount |
| 5 | Display field of the adjusted modulator position | 6 | Knurled ring for adjusting the position of the modulator disk |
| 7 | Modulator disk with 5 positions for condenser modules | | |

3.2.14 Stages

3.2.14.1 Rackless Mechanical Stage, 75x50 R

Purpose Mechanical stages are used for fixing and positioning the sample for examination.

Position The mechanical stages are mounted on the stage carrier of the stand.

Function The sample is fixed on the stage by means of the sample holder. For this purpose, the sample holder is equipped with a spring lever.

The sample is positioned in the beam path by means of the two coaxial drives in X and Y direction. The adjustment range can be read off the respective vernier scale.

The following features and controls are available:

- rackless stage
- coaxial drives in X and Y adjustment on the right (R), optionally on the left (L)
- travel range 75x50mm
- with hardcoat anodized surface

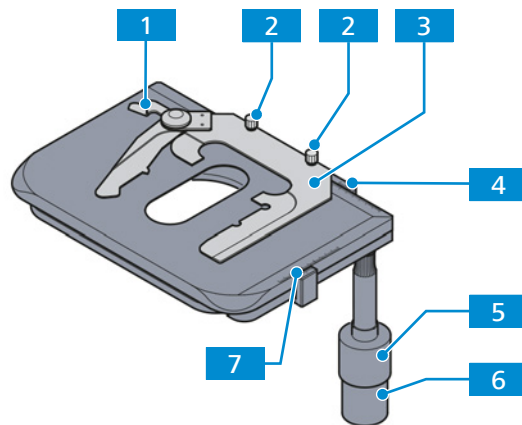

Fig. 23: Rackless mechanical stage, 75x50 R

- | | |
|--|--|
| <p>1 Spring lever</p> | <p>2 Knurled screw (2x) for fixing the sample holder to the stage</p> |
| <p>3 sample holder for double slides 76x26</p> | <p>4 Vernier scale for display of the adjustment range in X</p> |
| <p>5 Coaxial knurled knob for Y adjustment</p> | <p>6 Coaxial knurled knob for X adjustment</p> |
| <p>7 Vernier scale for display of the adjustment range in Y</p> | |

3.2.14.2 Rotary Stage Pol 360° with Clamping Device

Purpose Rotary stages are used for fixing and positioning the sample for examination in polarized light.

Position The rotary stages are mounted on the stage carrier of the stand.

Function The sample is fixed on the stage by means of the clamping device.

The following features and controls are available:

- 360° rotation with lock
- click stop every 45°; enabled or disabled via the control knob

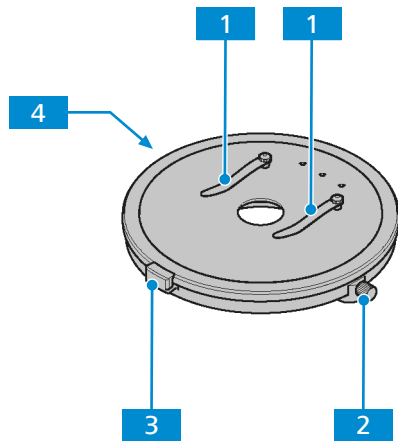

Fig. 24: Rotary Stage Pol 360° with clamping device

- | | |
|--|---|
| <p>1 Clamping device</p> <p>3 Click stop every 45°</p> | <p>2 Knurled screw for locking the rotation, 360° rotation possible</p> <p>4 Control knob to enable/disable the clip stop function (on the bottom side)</p> |
|--|---|

3.2.15 Reflector Turret

Purpose The reflector turret is used to hold the push-and-click (PGC) reflector modules and to swivel the desired reflector module into the beam path.

Position The reflector turret is mounted on the upper part of the stand above the nosepiece.

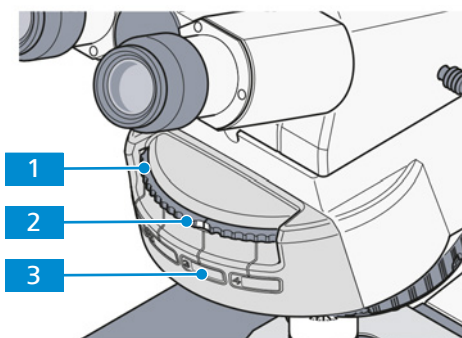

Fig. 25: 4-positions reflector turret

- | | |
|--|---|
| <p>1 Knurled ring to swivel the desired reflector module into the beam path</p> <p>3 Field for the supplied stickers, the stickers can be labeled with the filter combination data of the reflector module and pasted on the corresponding field</p> | <p>2 Marking on the knurled ring, indicates which reflector module is in the beam path</p> |
|--|---|

3.2.16 Storage Compartment

Purpose The storage compartment is used to store tools and the power cord (rolled up for transport).

Position The storage compartment is located at the back of the stand.

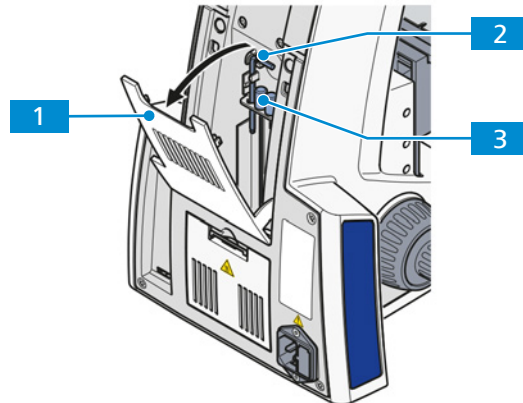

Fig. 26: Storage compartment

- | | | | |
|----------|-------------------------------|----------|-----------------------|
| 1 | Cover flap | 2 | Angled hex key (3 mm) |
| 3 | Two knurled hex keys (1.5 mm) | | |

3.3 Light Manager Function

The Light Manager (LM) function saves the ratios of the set light intensities between different combinations of objective and reflector turret positions for a given light source.

When changing the light intensity of one objective/reflector combination, the light intensities of other combinations will also change according to the set ratios.

This ensures that users don't need to repeatedly set up light intensities for each objective/reflector combination when switching between samples which require different illumination intensity.

After switching on the microscope, the previous setting of the Light Manager will be restored.

3.4 Microscopy and Contrast Techniques

The availability of microscopy and contrast techniques depends on the microscope type and the configuration.

3.4.1 Transmitted Light Brightfield Microscopy Using the KÖHLER Method

Transmitted light brightfield microscopy is the most common of all optical microscopy methods, since it can be used to quickly and easily examine high-contrast or stained samples (e.g. blood smears).

In order to obtain an image as close as possible to the object, not only the so-called direct beam bundles but also the indirect ones, i.e. the beam bundles diffracted and scattered at the preparation details, are of essential importance. According to ABBE, the larger the indirect beam components are, the more true to the object the microscopic image is.

The best performance of the microscope, and especially its objective, is achieved when the condenser, field diaphragm and aperture diaphragm are adjusted in accordance with the KÖHLER illumination principles.

3.4.2 Transmitted Light Darkfield Microscopy Using the KÖHLER Method

In the transmitted light darkfield microscopy you basically illuminate the sample with an illumination aperture which is higher than the one of the objective you are using.

In darkfield microscopy, only the diffracted and scattered light portions which are important for the imaging procedure get into the objective, whereas the indirect unaffected light beams are directed past the objective. Thus a resolution of fine structures can be achieved which is below the resolution capacity of a light microscope. The fine structures now appear bright and incandescent on a dark background.

Darkfield samples need to be kept impeccably clean, more so than samples for any other method. A fingerprint, dust or any dirt particle can have a negative effect, as they brighten the background and reduce the contrast of the object image.

3.4.3 Transmitted Light Phase Contrast Microscopy

The phase contrast method is ideal for examining thin uncolored samples, e.g. individual cells of cell cultures. Generally, the human eye cannot detect phase differences (variations in refractive index or thickness) within the different cell components.

The phase contrast method uses the optical modulators "annular phase diaphragm" and "phase ring" to convert the small phase differences in intensity differences which are visible to the human eye. The interference of different beams in the intermediate image is important for the generation of such images.

With the aid of the optically defined ring channel "annular phase diaphragm and phase ring", the bright direct light portions are attenuated and provided with a constant phase shift. The indirect light portions, however, which are diffracted by different cell particles, bypass this optical channel and their phase is affected by the difference in the sample's refractive index and thickness.

In the intermediate image plane, the partial beams are thus differently affected and achieve interference and strengthen or weaken each other (constructive and destructive interference) – depending on their phase. As a result, these interferences create image contents with intensity differences visible to the human eye.

3.4.4 Transmitted Light Polarization

The transmitted light polarization method is used for samples which change the polarization of the light. Such samples are called birefringent. Examples include crystals, minerals or polymers. If such birefringent substances are observed between crossed polarizers, the birefringent portion of the sample appears bright while its surroundings remain dark.

3.4.4.1 Detecting Birefringence

A birefringent substance can be recognized by turning the sample by 360° between crossed polarizers. The sample should show four bright and four dark appearances during the turning procedure. During the turning procedure, interference colors appear that range from gray (mostly for biological samples) through white, yellow and red until blue, depending on birefringence, thickness as well as sample orientation. The interference colors may be of the first or of a higher order.

3.4.4.2 Determination of the Polarization Direction

The determination of the polarization direction of n_v or n_v' respectively (polarization direction with the absolute or relative largest index of refraction) and n_a or n_a' respectively (polarization direction with the absolute or relative smallest index of refraction) relative to the morphological directions, e.g. of crystal surfaces, crystal needles or fibers, provide an important signature of the material. This method is also used in the diagnosis of bio-crystals (e.g. gout and pseudo-gout).

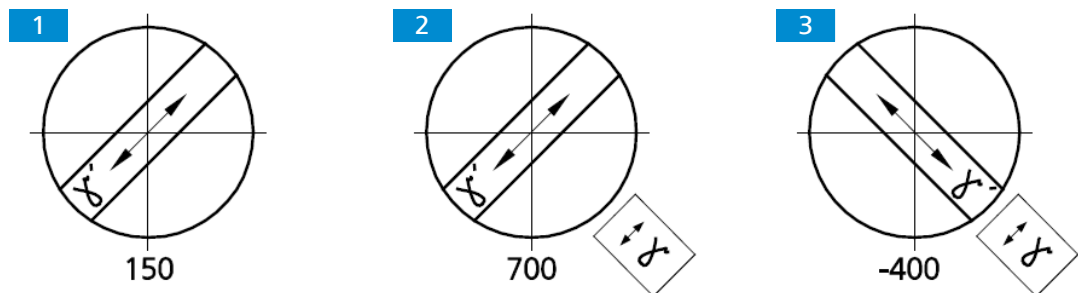

Fig. 27: Determining the polarization direction n_v using a synthetic fiber as an example

When the lambda compensator is put in, the sample changes its color depending on its orientation (northeast-southwest or northwest-southeast). Like the sample, the lambda compensator is a birefringent object, but it has a defined path difference of 550 nm and a maximum oscillation direction n_v pointing strongly to northeast-southwest.

The changes in color are based on optical interference. It is necessary to compare the interference colors (path differences) in both diagonal positions (northeast-southwest and northwest-southeast).

The path difference results from the interference of the polarization of the sample and the polarization of the lambda compensator.

The largest path difference occurs when the polarization direction of the sample or the absolute or relative largest index of refraction (n_v or n_v') is parallel to the largest polarization direction of the lambda compensator. The sample appears then e.g. in blue-green **2**.

The smallest path difference occurs when the direction of polarization of the sample with the absolute or relative smallest index of refraction (n_a or n_a') is perpendicular to the polarization direction of the lambda compensator. The sample then appears e.g. yellow **3**.

The gray-white color appearing first in the bright position in the above example **1** corresponds to a path difference of 150 nm according to the Michel-Lévy color chart).

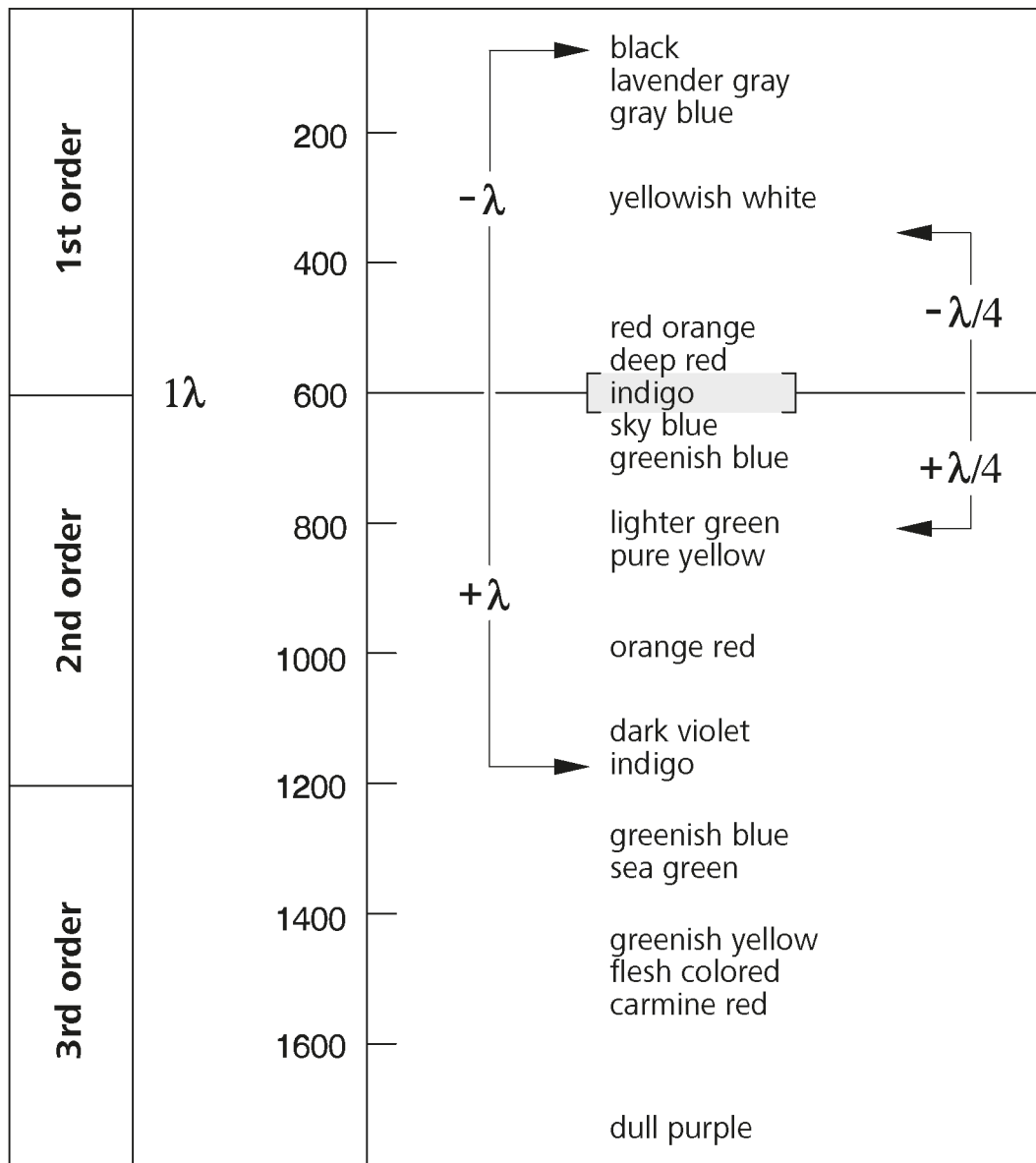

Fig. 28: Schematic diagram of the color charts developed by Michel-Lévy

When the lambda compensator is brought into the beam path, the non-birefringent "surroundings" of the synthetic fiber appear dark red, which corresponds to the path difference of the compensator of 550 nm (1st order interference color for the path difference of 550 nm corresponds to 1λ).

If the polarization direction (n_v or $n_{v'}$) of the birefringent sample to be examined is parallel to the principal polarization direction (n_v) of the lambda compensator, i.e. in the northeast-southwest direction, the path difference of the sample (e.g. gray-white: 150 nm) and the path difference of the lambda compensator (red: 550 nm) add up. This results in a color change of the sample from grayish white to greenish-blue (resulting path difference = 700 nm).

If the polarization direction of the birefringent sample to be examined is perpendicular to the principal polarization direction of the lambda compensator, i.e. in the northwest-southeast direction, the path difference of the sample (e.g. gray-white: 150 nm) is subtracted from the path difference of the compensator (red: 550 nm). In this case, the interference color of the sample visibly changes from gray-white to orange (resulting path difference = 400 nm).

3.4.4.3 Measuring Path Differences

Measuring compensators are required for the accurate measurement of path differences. These compensators reset, i.e. compensate the path difference produced by the sample to zero (first order black). While the addition position as well as the subtraction position are of interest for the methods described above, only the subtraction position is relevant for measurements. Path differences in the sample can assume very small values ($1/50 \lambda$ or 10 nm) and very large values (greater than 10λ or approx. 5500 nm and more) and thus determine the compensator appropriate for the measurement.

The suitable compensator is determined as follows:

- If more or less strong interference colors appear on the sample, the path difference ranges approximately between $1/2 \lambda$ and 5λ .
The suitable compensator is:
B 0-5 λ tilting compensator
- If the sample-side color changes from light gray/white to a strong interference color, when a lambda compensator (473704-0000-000) is inserted in the compensator slot, the path difference is $(1/4 - 1/2) \lambda$.

NOTICE A prerequisite for the occurrence of the color change effect may be the evaluation in two sample positions rotated at an angle of 90° from one another. For this purpose, rotate the centered stage (by 2 click stops).

The suitable compensator is:

B 0-5 λ tilting compensator

or the DE SENARMONT compensation method up to 1λ using the 546/4 nm SENARMONT compensator.

NOTICE The DE SENARMONT compensation method requires the use of the rotatable analyzer.

- After insertion of the lambda compensator and rotation of the sample by 90° , the interference color remains white; in this case, however, it is a "higher-order white" and thus the path difference is $> 5 \lambda$.
The suitable compensator is:
K 0-30 λ tilting compensator
- A dark gray appearing as the interference color indicates a very small path difference ($\lambda/10$ or 54.6 nm).

3.4.4.4 Circular Polarization Contrast

Unlike standard polarization contrast, circular polarization contrast does not show any dark (extinction) positions that depend on the angle of rotation (azimuth) of the sample relative to polarizer or analyzer. This means that, while you are rotating the stage, the image will always look the same, as there are no bright and dark positions. With optical anisotropy all transparent samples show the interference colors that are characteristic to them.

3.4.4.5 Determining the Optical Character of Crystals

For the classification (and thus identification) of crystalline material – instead of the observation of the sample itself – the analysis of an interference image in the objective pupil provides the more valuable information. This image is visible in the eyepiece when an additional lens (so-called Bertrand lens) is switched on. Alternatively, the auxiliary microscope or a diopter may be used to view the interference image.

In contrast to orthoscopy, this is referred to as conoscopy, because the illumination is ideally provided by a wide open cone. In practice this means that the aperture diaphragm is fully open and the objective should likewise have a high aperture.

Crystal analysis is used to determine the optical character of transparent and weakly absorbent crystals. This method is also referred to as conoscopy.

Its main application is classic mineral microscopy. However, synthetic crystals, industrial minerals and plastics (e.g. films) can also be identified and characterized.

In the case of uniaxial crystals, the most favorable orientation for conoscopic viewing is obtained with those sample features (e.g. of a thin section) that in orthoscopic viewing change the brightness as little as possible. In this case, the direction of viewing and the optical axis are parallel. The same applies to biaxial crystals if viewed in or approximately in the direction of one of the two optical axes.

Crystalline anisotropic samples can be separated into optical uni- and biaxial samples, in each case with an "optically positive" or "negative" character.

Uniaxial crystals display a **black cross** when the optical axis is parallel to the direction of view. Depending on the level of birefringence and sample thickness, concentrically arranged colored interference rings (so-called isochromes) may appear (see also table below, second row).

The lines of this black cross remain closed when the stage is rotated. Depending on the section it may lie within or outside the displayed objective pupil.

With optically biaxial crystals, the cross resolves into two dark hyperbola branches (the so-called isogyres) depending on stage rotation, which are surrounded by colored interference patterns depending on the amount of birefringence and sample thickness (suggestive of the figure "8").

Inserting a lambda compensator or lambda/4 or a 0-4 lambda wedge compensator in the compensator slot with the initial state of the axial figure being as illustrated in the table below results in the following changes in color (shown schematically as blue and yellow areas) to the axial figure, thus allowing differentiation in "optically positive" and "optically negative".

	Optically uniaxial		Optically biaxial		
	Positive	Negative	Positive	Negative	
Lambda plate (white → blue → yellow)					+ = Blue - = Yellow
Quartz wedge (direction of motion at insertion)					Arrow = Direction of movement
Lambda/4 plate (position of black spots)					

Tab. 1: Determining optical character

In the case of less favourable sections in which the cross-hair center is optically uniaxial or the isogyres are optically biaxial samples outside the objective pupil, an assessment is possible as follows:

- If the black isogyres are **straight** and they run parallel to the pupil (in relation to the cross-hairs), the sample is **optically uniaxial**.
- If the black isogyres are **curved lines** which wander on a circular path through the pupil, the sample is **optically biaxial**.

Info

Axial figures can often be better displayed with circular polarization. In particular, the axis angle of optically biaxial samples (quasi the distance between the isogyres) can be determined more clearly. The optical character can also be determined. The lambda compensator (6x20mm), arranged in the compensator slot, is used for this purpose.

Info

Two storage compartments for compensators (6x20) are located on the back side of the conoscopy stand.

3.4.5 Transmitted Light Polarization for Conoscopic Observation

The determination of the optical character of transparent and weakly absorbent crystals is used to diagnose crystals. This method is also termed conoscopy. Its main application is classical mineral microscopy. However, it also facilitates the identification and characterization of synthetic crystals, industrial minerals and plastics (e.g. films).

For the classification (and thus identification) of crystalline matter, the examination of the interference image in the objective pupil delivers more valuable information than that obtained by viewing the sample itself. The interference image becomes visible in the eyepiece if an additional optical system (fixed or focusing Bertrand lens or, in the basic version, the auxiliary microscope or diopter) is used.

In contrast to orthoscopy, this technique is called conoscopy, because here the sample is ideally illuminated through a wide-open cone. In practical microscopic work, this means that the condenser front lens (0.9) must be in the light path, the aperture diaphragm fully open, and the objective, too, should be a high-aperture type.

3.4.6 Reflected Light Brightfield Microscopy Using the KÖHLER Method

Reflected light brightfield microscopy is the easiest and most commonly used RL-microscopy method. It is used to examine optically opaque samples or samples as e.g. cut, polished, etched metal or ores.

In order to obtain an image as close as possible to the object, not only the so-called direct beam bundles but also the indirect ones, i.e. the beam bundles diffracted and scattered at the preparation details, are of essential importance. According to ABBE, the larger the indirect beam components are, the more true to the object the microscopic image is.

The cone of light emerging from the reflected light light source is reflected on a color-neutral beam splitter before it passes through the objective which is focused on the sample surface (so-called condenser function). The objective collects the light reflected on the sample and creates, with the tube lens, the microscopic intermediate image. This image can then be examined visually or documented using a camera.

3.4.7 Reflected Light Darkfield Microscopy Using the KÖHLER Method

The reflected light darkfield method is applied when samples are examined, which do not have areas with different reflectivity (ideal brightfield samples), but which show deflections (as scratches, cracks, dust particles etc.) on the plane surface. All such light-scattering details appear bright in the darkfield, while the reflective plane areas remain dark.

3.4.8 Reflected Light Polarization Microscopy

Reflected light polarization is a contrasting method suited for cut, polished surfaces of mineral ore, coal, ceramics, special metals and alloys. Depending on the orientation of the crystals and the sample details, the cut surfaces often react differently when reflected in linearly polarized light.

The illumination light is polarized by the polarizer before passing through the objective onto the sample surface where it is reflected. Then the beam parts experience path differences depending on the structure and polarization of optical rotations which, when passing through the analyzer, are represented by different shades of gray. With the aid of a compensator with a λ -plate the gray contrast can be converted into a color contrast.

Even when examining "dark" sample surfaces, a rotatable $\lambda/4$ plate in front of the objective (antireflective cap) helps eliminate the reflections which are inevitable when working with objectives with very low magnification.

A sample is bireflectant when the sample details show differences in brightness and color which change when the direction of vibration of the polarizer or the stage is rotated. For samples with low bireflectance using the analyzer with a rotatable lambda plate is recommended.

3.4.9 Reflected Light Fluorescence Microscopy

The reflected light fluorescence method is used to show fluorescent substances in typical fluorescent colors in high contrast. The light originating from a high-performance light source in a reflected light fluorescence microscope passes through a heat protection filter onto an excitation filter (bandpass). The filtered short-wave excitation radiation is reflected by a Dichroic Beam splitter and is focused on the sample through the objective. The sample absorbs the short-wave radiation before emitting longer-wave fluorescence radiation (Stokes' Law). This radiation is then captured from the image side by the objective and passes through the Dichroic Beam splitter. Last, the beams pass through a emission filter (longpass/bandpass) and only the long-wave radiation emitted by the sample passes.

The spectra of the excitation and the emission filter must match very closely. They must be inserted in a Reflector Module FL EC P&C reflector module together with the according Dichroic Beam splitter.

4 Installation

Perform only the installation work described in this document. All other installation work not described may only be carried out by an authorized ZEISS service representative.

4.1 Unpacking and Setting Up the Microscope

- Procedure**
1. Open the packaging and remove all components.
 2. When unpacking any delivery of ZEISS, always verify that all components listed on the delivery note are present and undamaged.
 3. Set up the stand on a vibration-free, level, hard and non-combustible surface.

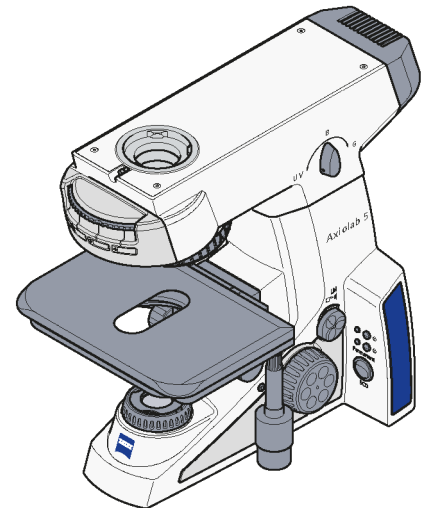

Info

It is recommended to keep the original packing and store it away for later use, e.g. for stowing the microscope during periods of non-use or for returning the microscope to the manufacturer for repair.

4.2 Assembling the Binocular Tube

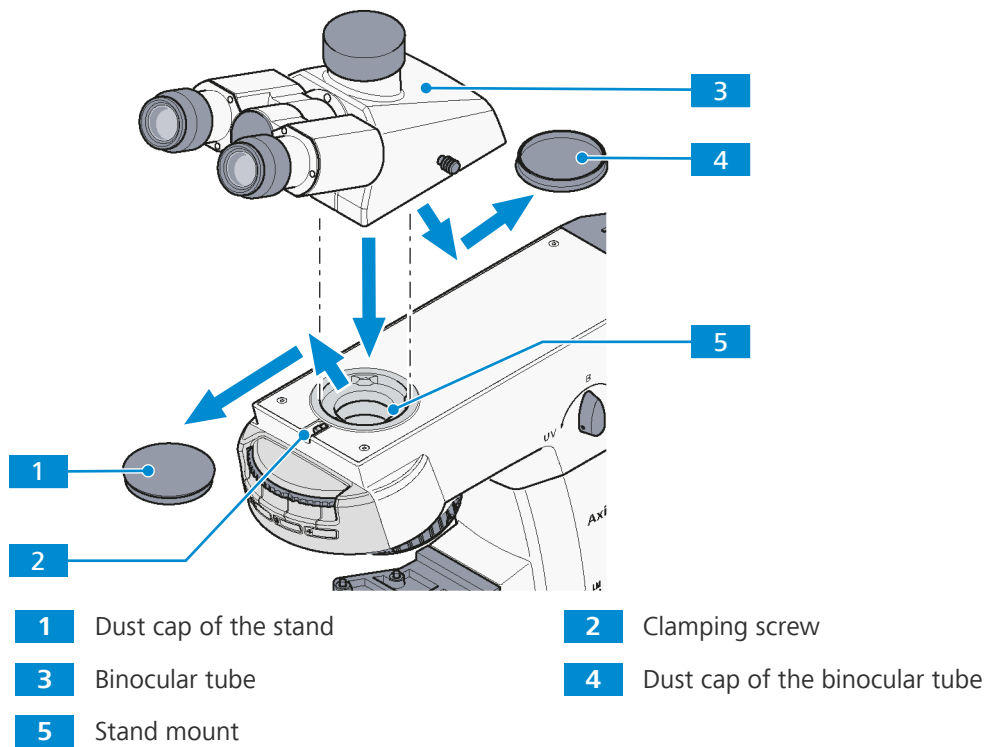

Parts and Tools  Hex Key, 3.0 mm

Procedure

1. Loosen the clamping screw **2**.
2. Remove the dust cap **1** from the dovetail ring mount on the stand side.
3. Remove the dust cap **4** from the underside of the binocular tube **3**.
4. Hold the binocular tube at an angle, insert it with the dovetail ring into the stand mount **5** and turn into a horizontal position.
5. Rotate the binocular tube into the desired observation position.
6. Re-tighten the clamping screw with the hex key.

4.3 Assembling the Binocular Tube with an Intermediate Plate

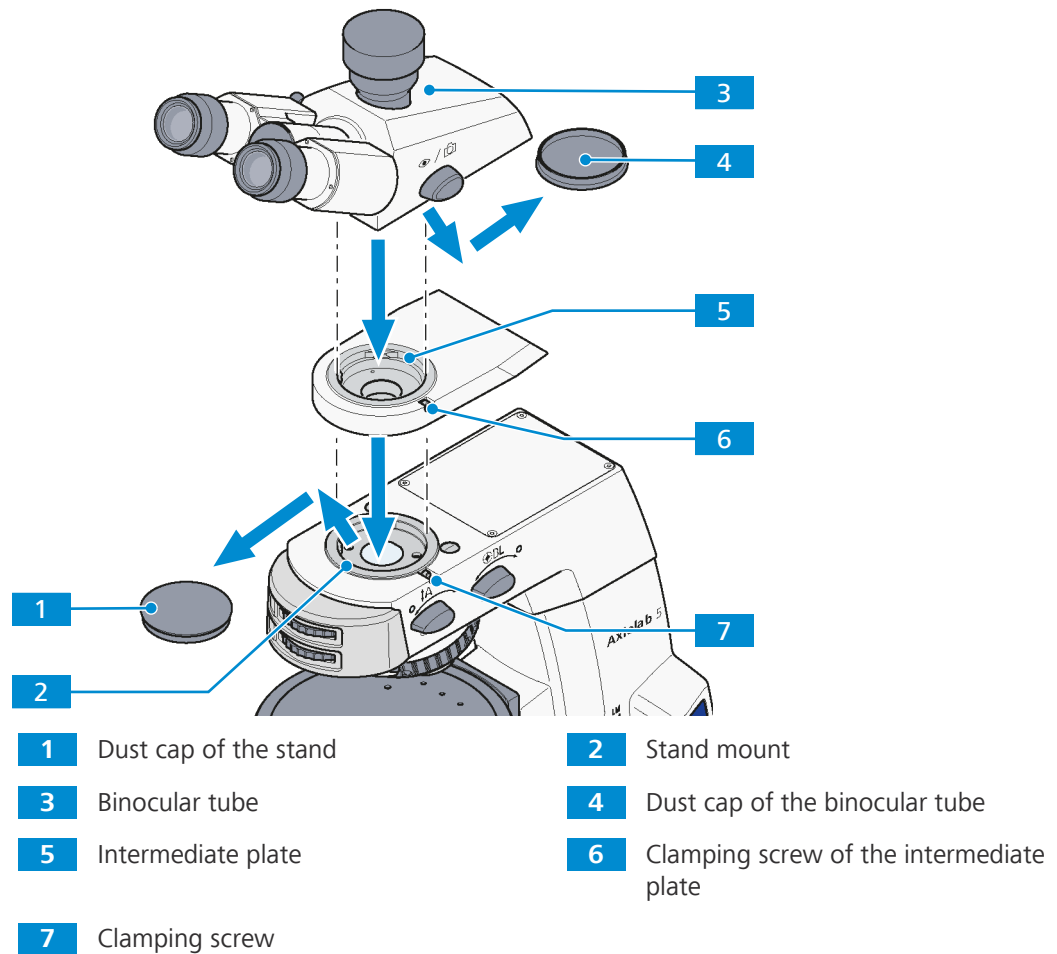

Parts and Tools 🔧 Hex Key, 3.0 mm

- Procedure**
1. Loosen the clamping screw of the stand **7**.
 2. Remove the dust cap **1** from the dovetail ring mount on the stand side.
 3. Insert the intermediate plate **5** with its dovetail ring into the stand mount **2**.
 4. Align it to the stand and tighten the clamping screw of the stand **7**.
 5. Remove the dust cap **4** from the underside of the binocular tube **3**.
 6. Hold the binocular tube **3** at an angle, insert it with the dovetail ring into the intermediate plate **5** and turn into a horizontal position.
 7. Rotate the binocular tube into the desired observation position.
 8. Re-tighten the clamping screw of the intermediate plate **6** with the hex key.

4.4 Assembling Components to the Binocular Tube

The following components can be inserted into the tube:

- eyepieces
- auxiliary microscope
- pinhole diaphragm

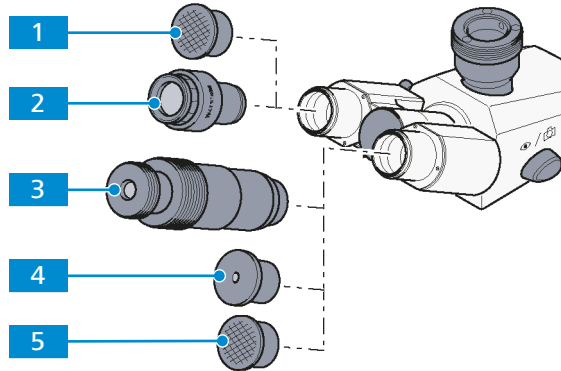

- | | |
|-------------------------------|----------------------------|
| 1 Dust cap | 2 Eyepiece |
| 3 Auxiliary microscope | 4 Pinhole diaphragm |
| 5 Dust cap | |

- Procedure**
1. Remove both dust caps **1** / **5** from the tube.
 2. Remove both eyepieces **2** from the box and insert them into the eyepiece socket of the tube to the stop.
NOTICE Before inserting Pol eyepieces with tubes without upright reticles, the orientation screw on the reverse side of the eyepieces must be unscrewed. The eyepieces cannot otherwise be fully inserted.
 3. Instead of an eyepiece insert an auxiliary microscope **3** or pinhole diaphragm **4** in one eyepiece socket.

Proceed in the reverse order for removal.

4.5 Assembling Objectives

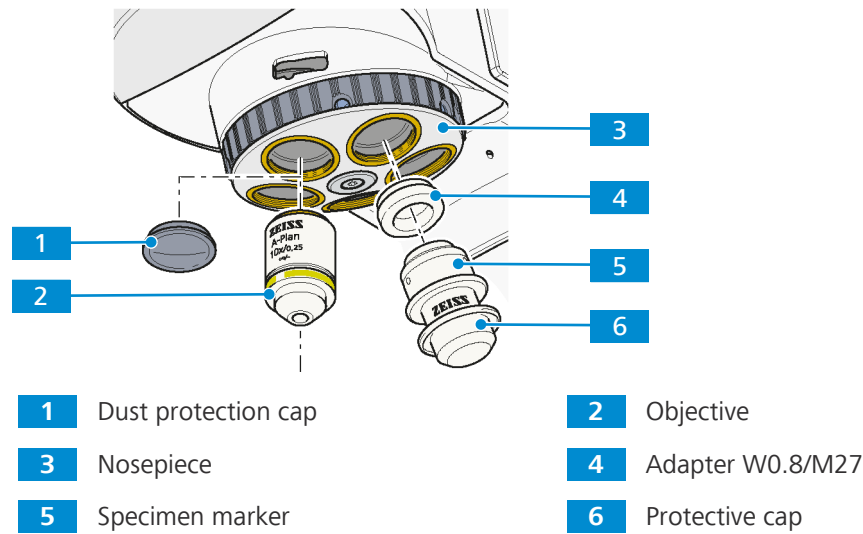

Prerequisite ✓ Adapter W0.8/M27 is required when using W0.8 objectives or the sample marker.

Procedure 1. Move mechanical stage to lower stop using the focusing drive.

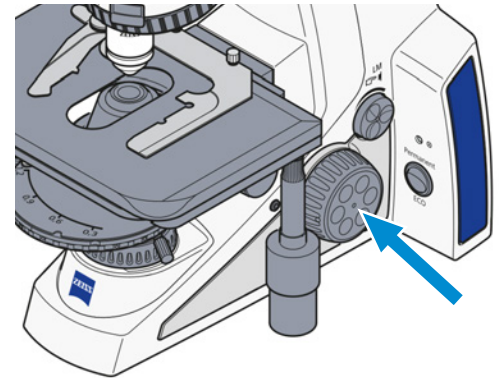

2. Remove the dust protection caps **1** from the appropriate openings in the nosepiece.
3. Remove objectives **2** from the case and screw them into the nosepiece **3**.
4. Carefully screw the objective into the opening. Start with the smallest magnification factor (set up clockwise) in nosepiece position 1.
5. Make sure it engages properly in the nosepiece's thread.
6. Instead of an objective, the sample marker **5** with an adapter W0.8/M27 **4** can be screwed on in any desired nosepiece position.
7. Apply the protective cap **6** to prevent sample marker from drying out.
8. Always replace the dust protection caps on any empty positions on the nosepiece.

4.6 Assembling Condensers

4.6.1 Assembling the Condenser 0.9/1.25 BF, DF, Ph1, Ph2, Ph3 with Modulator Disk

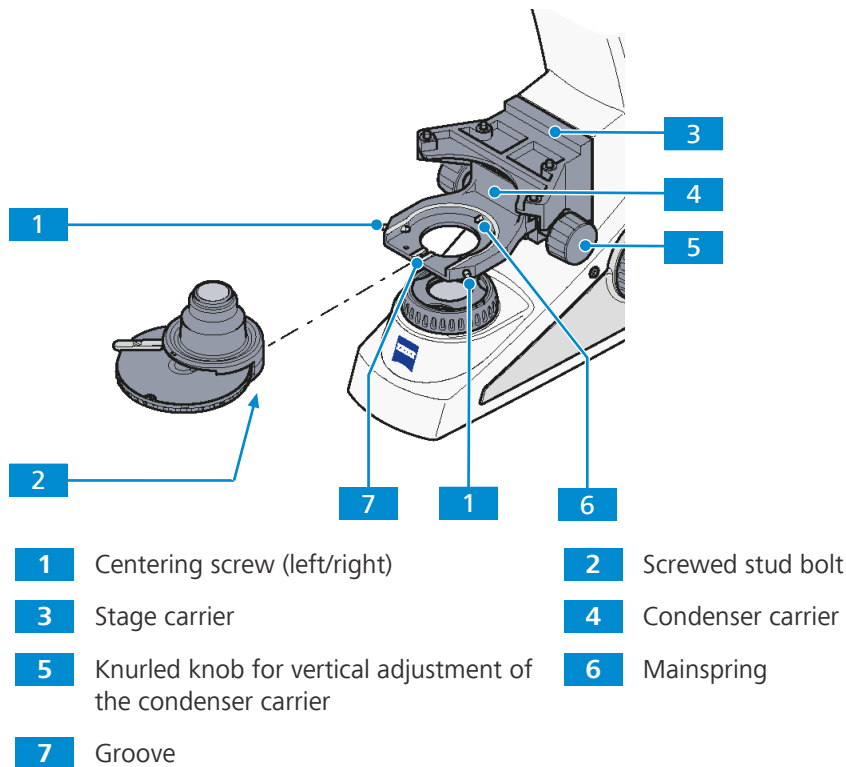

- Procedure**
1. Carefully move the stage carrier **3** with the focusing drive to the upper stop position.
NOTICE Make sure that the stage does not collide with the objective.

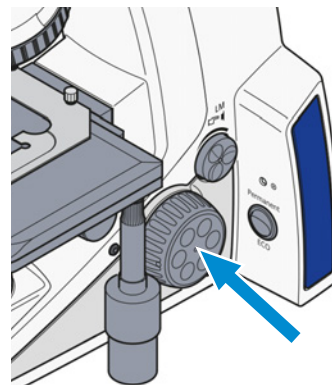

2. Unscrew both centering screws **1** on the condenser carrier until their ends are no longer visible.
3. Using the knurled knob for vertical adjustment **5**, push the condenser carrier down as far as it will go.
NOTICE If using a low-power system, make sure that this does not come to rest on the luminous-field diaphragm.
4. Insert the condenser between the condenser carrier **4** and the stage carrier **3**. In doing so, align the screwed stud bolt **2** on the underside of the condenser with the groove **7** of the condenser carrier.
5. Press the condenser with the dovetail ring against the mainspring **6** of the condenser carrier until the condenser sits horizontally on the condenser carrier.
6. Screw in the centering screws until they engage with the dovetail ring of the condenser.

4.6.2 Assembling the Dry Darkfield Condenser

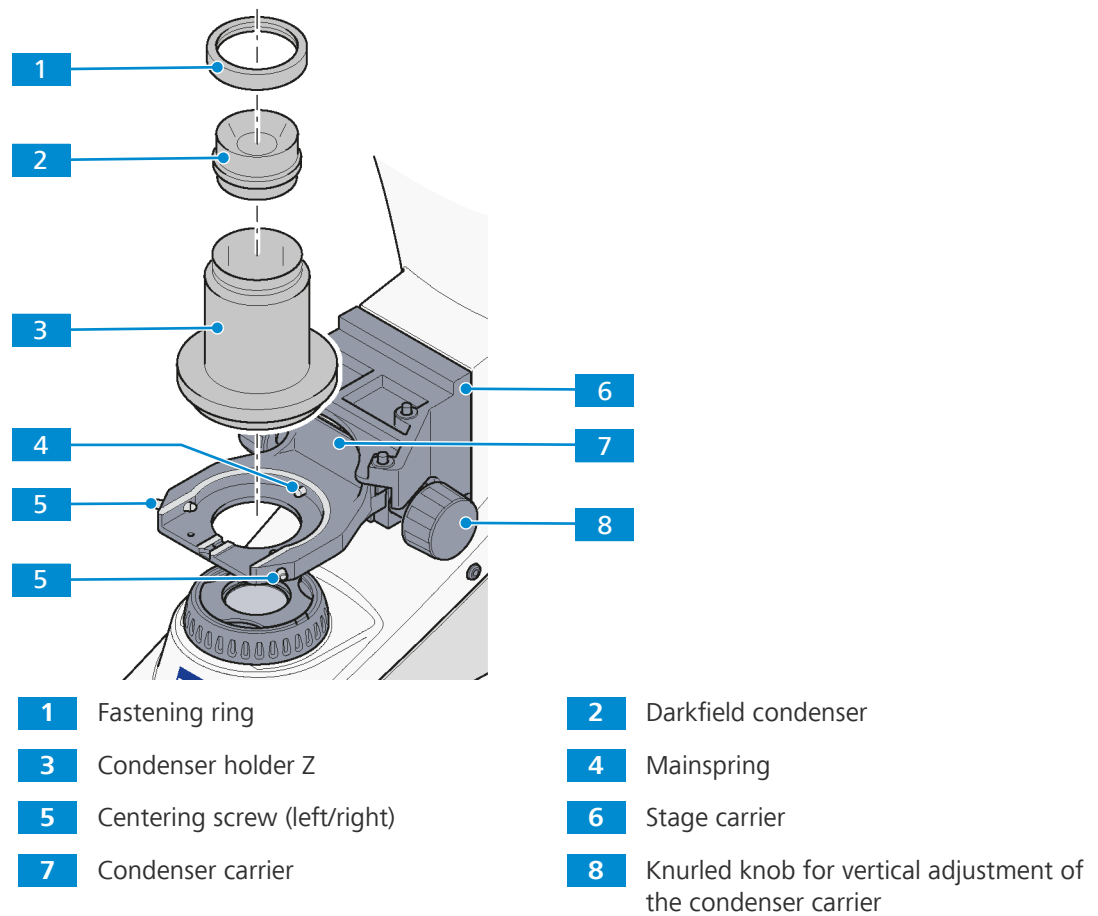

Procedure

- Carefully move the stage carrier **6** with the focusing drive to the upper stop position.

NOTICE Make sure that the stage does not collide with the objective.

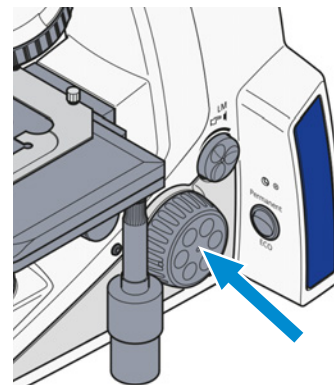

- Using the knurled knob **8** for vertical adjustment, push the condenser carrier down as far as it will go.
NOTICE If using a low-power system, make sure that this does not come to rest on the luminous-field diaphragm.
- Insert the darkfield condenser **2** in the condenser holder Z **3**.
- Fix the darkfield condenser with the fastening ring **1**.
- Unscrew both centering screws **5** on the condenser carrier **7** until their ends are no longer visible.
- Press the condenser holder Z with the dovetail ring against the mainspring **4** of the condenser carrier until the condenser holder Z sits horizontally on the condenser carrier.
- Screw in the centering screws until they engage with the dovetail ring of the condenser holder Z.

4.6.3 Assembling the Condenser, Chromatic-aplanatic 0.9 BF DF PhC DIC

Info

If an additional component, e.g. a polarizer, has been mounted beneath the condenser carrier, the stage carrier should be removed before installing the condenser.

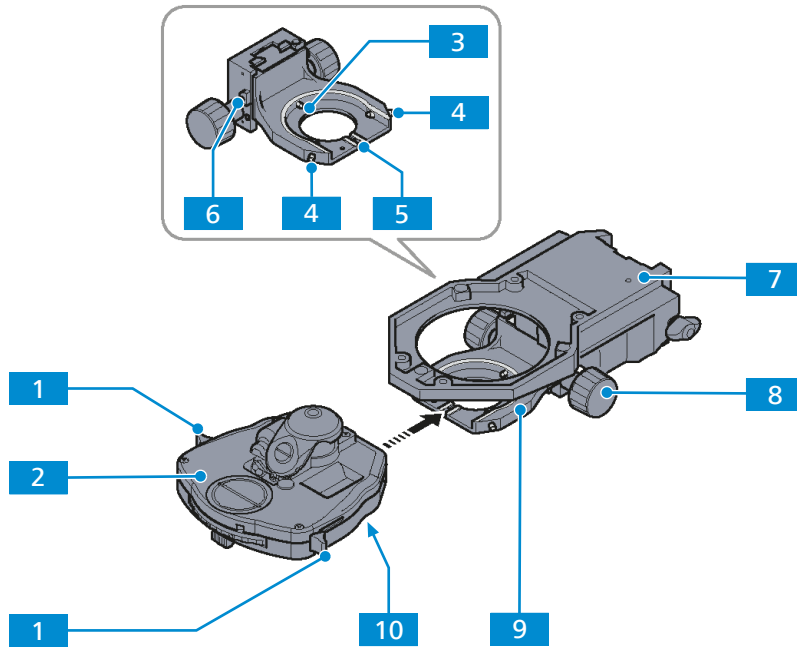

Fig. 29: Installing the condenser, achromatic-aplanatic 0.9 BF DF PhC DIC

- | | |
|--|--|
| 1 Lever for swivelling the front lens in/out (left/right) | 2 Condenser |
| 3 Mainspring | 4 Centering screw (left/right) |
| 5 Groove | 6 Clamping screw |
| 7 Stage carrier | 8 Knurled knob for vertical adjustment of the condenser carrier |
| 9 Condenser carrier | 10 Screwed stud bolt |

Procedure

- Carefully move the stage carrier **7** to the upper stop position. Use the focusing drive.

NOTICE Make sure that the stage does not collide with the objective.

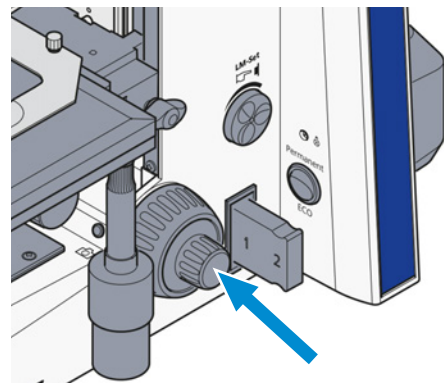

- Swivel out the front lens on the condenser **2** using the lever **1**.
- Unscrew both centering screws **4** on the condenser carrier **9** until their ends are no longer visible.
- Loosen the clamping screw **6** of the condenser carrier until the maximum vertical adjusting range is usable.

5. Using the knurled knob **8** for vertical adjustment, push the condenser carrier down as far as it will go.
NOTICE If using a low-power system, make sure that this does not come to rest on the luminous-field diaphragm.
6. Insert the condenser between the condenser carrier and the stage carrier **7**. In doing so, align the screwed stud bolt **10** on the underside of the condenser with the groove **5** of the condenser carrier.
7. Press the condenser with the dovetail ring against the mainspring **3** of the condenser carrier until the condenser sits horizontally on the condenser carrier.
8. Screw in the centering screws **4** until they engage with the dovetail ring of the condenser.
9. Screw in the clamping screw **6** without clamping the vertical drive.

Proceed in the reverse order for removal.

4.6.4 Assembling the Modulator Disk in the Condenser 0.9 BF Pol

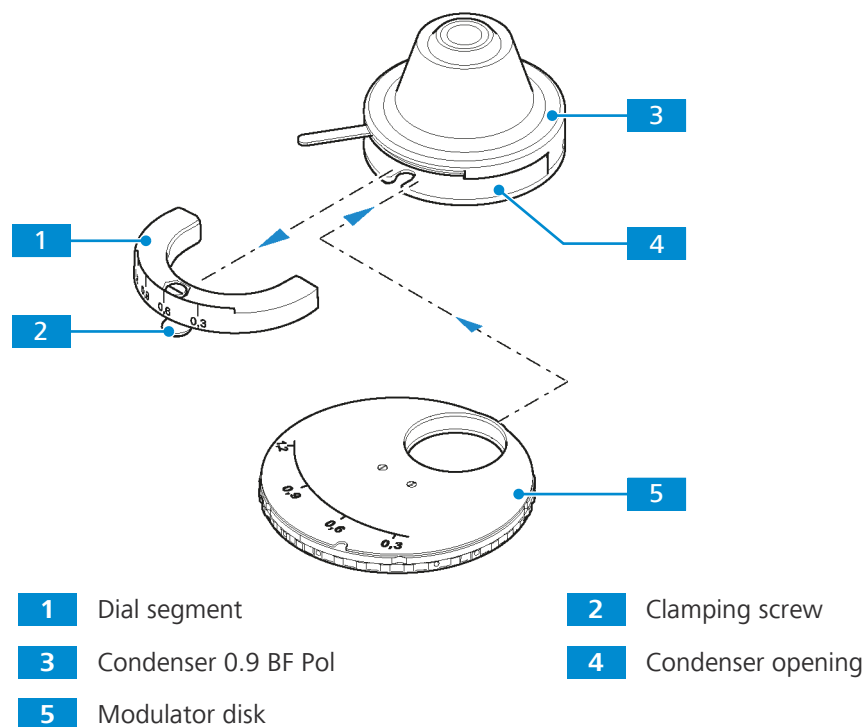

Parts and Tools  Hex Key, 3.0 mm

Prerequisite  The condenser **3** is removed from the condenser carrier [[▶ 54](#)].

- Procedure**
1. Loosen the clamping screw **2** of the condenser's dial segment **1** and pull out the dial segment.
 2. Slide the modulator disk **5** with its two-pronged forked opening pointing forward into the condenser opening **4**.
 3. Make sure that the disk engages in the guide on both inner sides of the condenser.
 → The guide serves as a stop for the modulator disk. The pin of the disk's clamping screw must slide into the orientation groove of the condenser.
 4. Tighten the disk's clamping screw.
 5. Replace the condenser in its carrier.

4.7 Loading the Reflector Turret

The reflector turret with four positions is firmly installed in the reflected light illumination module for fluorescence or materials stands.

4.7.1 Assembling Reflector Modules

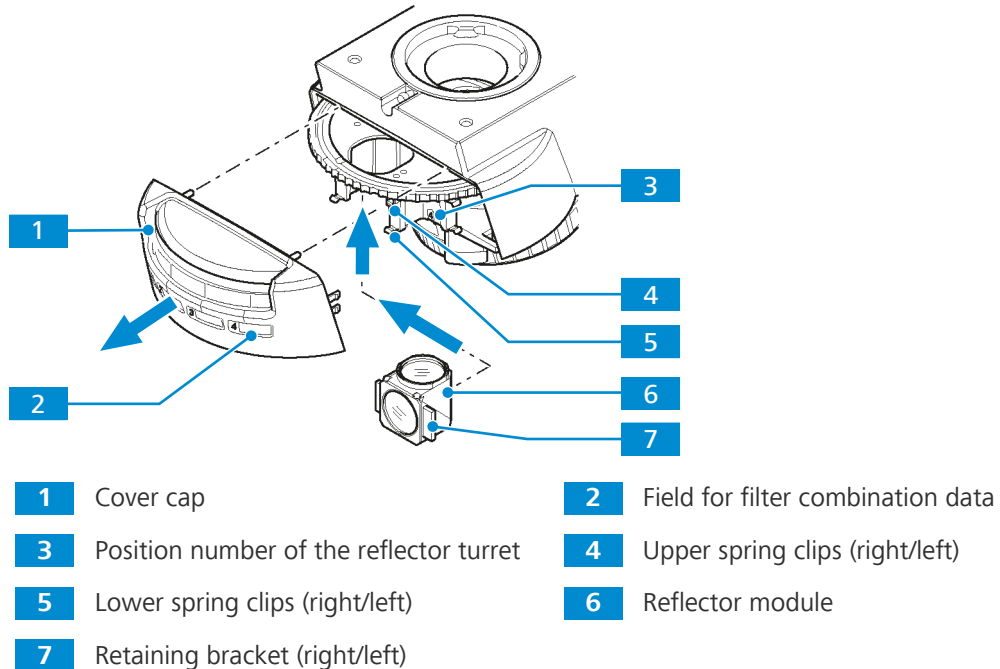

- Procedure**
1. Remove the cover cap **1** from the stand towards the front.
 2. Turn the reflector turret to the desired position **3**.
 3. Insert the reflector module **6** together with the retaining brackets **7** on the right and left diagonally from below into the upper spring clips **4** (right/left) of the reflector turret position.
 4. Apply pressure to the reflector module from below until it also securely engages with the lower spring clips **5** of the reflector turret position.
 5. Fit the cover cap onto the stand as straight as possible to avoid the knurled ring of the reflector turret becoming jammed and damaged.
 6. Apply pressure to the cover cap until the retaining brackets have engaged.
 7. Apply the supplied stickers with the filter combination data of the respective module to the corresponding field **2** of the cover cap (positions 1 to 4).

4.7.2 Removing Reflector Modules

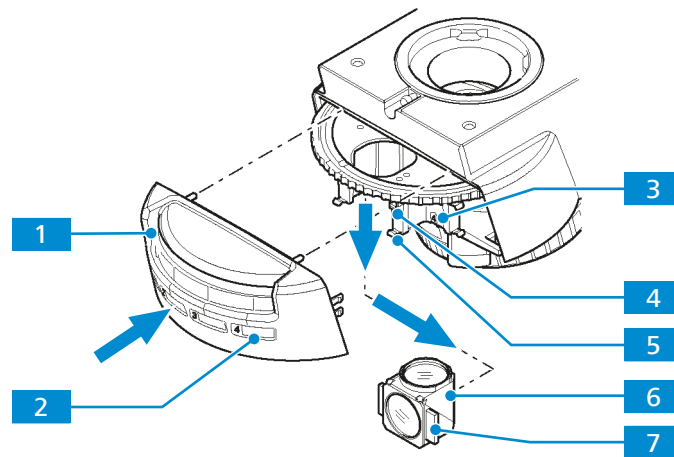

- | | |
|--|--|
| 1 Cover cap | 2 Field for filter combination data |
| 3 Position number of the reflector turret | 4 Upper spring clips (right/left) |
| 5 Lower spring clips (right/left) | 6 Reflector module |
| 7 Retaining bracket (right/left) | |

- Procedure**
1. Remove the cover cap **1** from the stand towards the front.
 2. Turn the reflector turret to the desired position **3**.
 3. Slightly tilt the reflector module **6** in order to detach it from the lower spring clips **5**, then from the upper spring clips **4** of the reflector turret using the retaining bracket **7**.
 4. Fit the cover cap onto the stand as straight as possible to avoid the knurled ring of the reflector turret becoming jammed and damaged.
 5. Apply pressure to the cover cap until the retaining brackets have engaged.
 6. Update the filter data on the sticker for the corresponding field **2** on the cover cap.

4.8 Connecting the Microscope to the Mains

Prerequisite ✓ The microscope is switched off.

- Procedure**
1. Connect the power cable to the mains socket of the stand.

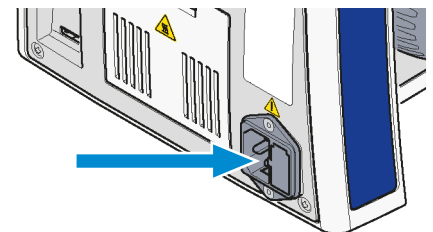

2. Connect the power cable to the mains.

5 Operation

This chapter describes switching on/off the microscope as well as the operating steps with the microscope.

Info

For additional information and detailed descriptions, refer to further applicable documents or ask your ZEISS Sales & Service Partner.

Info

Further information on the software and its operation is available in the software's online help.

5.1 Prerequisites for Commissioning and Operation

The following basic prerequisites are necessary for commissioning and operation:

- This document was read prior to commissioning or operation and kept for further use.
- The chapter **Safety** was read and understood.
- The operator is acquainted with the general Windows®-based programs.
- If required: Basic training and safety briefing were successfully completed.

5.2 Switching On the Microscope

WARNING

Skin or eye injury due to hazardous light emission

The light source belongs to Risk Group 3 as specified in IEC 62471 and emits LED radiation and UV radiation. Skin or eye injury can result from the exposure.

- ▶ Avoid any eye and skin exposure to the light-emitting aperture of the light source.
- ▶ Avoid exposure of skin to the radiation. Use suitable protective equipment/protective clothing if required.
- ▶ Before installing or removing the light source always make sure it is switched off.

Prerequisite ✓ The microscope is connected to a power socket.

Procedure 1. Switch the microscope on using the power switch **On/Off**.

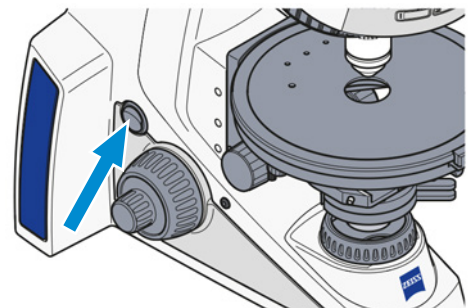

5.3 Adjusting

5.3.1 Adjusting the Position of the Eyepieces

Info

The adjustment of the interpupillary distance is correct when you see only one round image while looking through the two eyepieces.

- Procedure**
1. Set the interpupillary distance by rotating the eyepiece tubes symmetrically toward or away from one another.



2. Set the viewing height by swivelling the whole eyepiece unit a full 180 ° upwards or downwards.

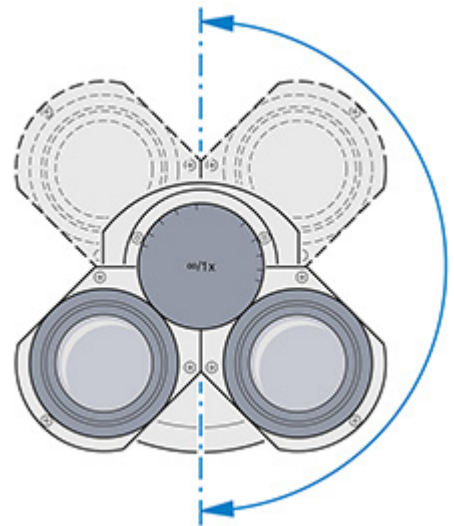

5.3.2 Adjusting for Ametropia when Using Eyepiece Reticles

- Prerequisite**
- ✓ Two adjustable eyepieces are installed
 - ✓ One eyepiece with reticle is installed.

- Procedure**
1. Focus on the line figure of the eyepiece reticle with the focusable eye lens of the adjustable eyepiece containing the eyepiece reticle.
 2. Focus on the microscopic image of a loaded sample with the focusing drive while observing with the eyepiece containing the eyepiece reticle.
 - Both the microscopic image and the eyepiece reticle are in focus now.
 3. Focus the microscopic image for the second eye with the focusable eye lens of the second eyepiece.
 - ↳ Both microscopic images including the eyepiece reticle are thus in focus. From this point, use only the focusing drive for any subsequent focusing activity.

5.3.3 Adjusting the Height Stop on the Condenser Carrier

Parts and Tools 🔧 Hex Key, 3.0 mm

- Prerequisite**
- ✓ The microscope is operational.
 - ✓ A sample is positioned on the stage.

Procedure 1. Loosen the set screw of the height stop.

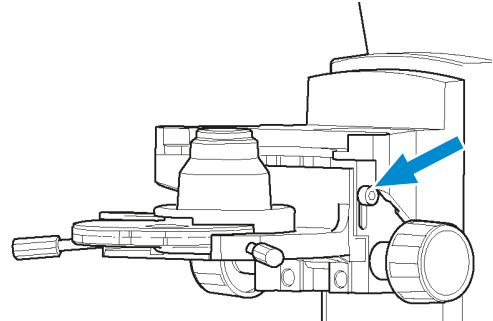

2. Focus the sample with the focusing drive.

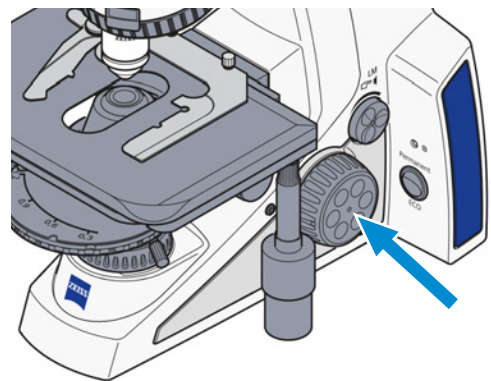

3. Close the luminous-field diaphragm.

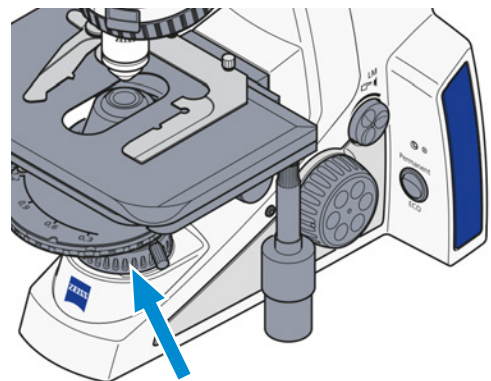

4. Adjust the condenser vertically until you get a sharp image.

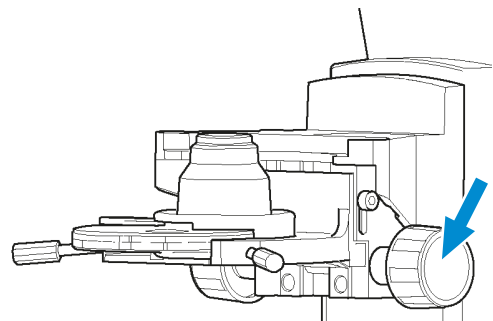

5. **NOTICE** The sample and the objective can be damaged when the sample is lifted out.
Carefully raise the condenser by a small amount without lifting out the sample.

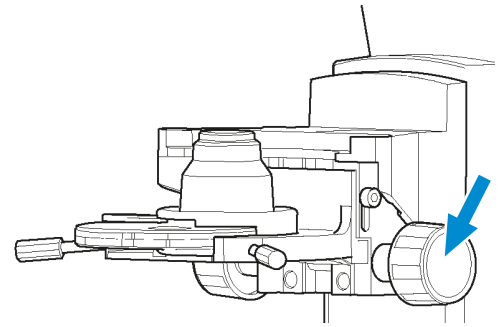

6. Tighten the set screw of the height stop.

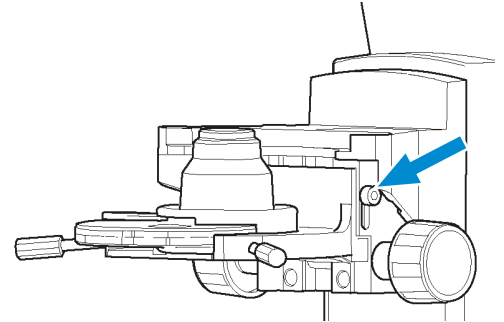

↳ The height stop is adjusted.

5.3.4 Using the Light Manager Function

5.3.4.1 Switching On and Off the Light Manager Function

Prerequisite ✓ The microscope is operational.

- Procedure** 1. Press one of the **Snap button** and the **Intensity/LM knob** simultaneously for at least 1.5 seconds.

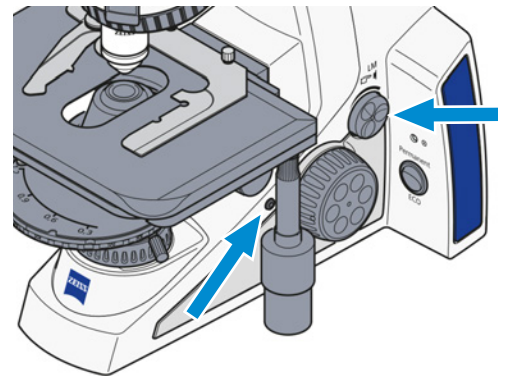

- The indicator light blinks in the following sequence, when the Light Manager is switched on: GREEN / GREEN / GREEN
- The indicator light blinks in the following sequence, when the Light Manager is switched off: GREEN / ORANGE / GREEN

5.3.4.2 Saving Light Intensity Ratios

- Prerequisite** ✓ The microscope is operational.
 ✓ The Light Manager function is *enabled* [▶ 61].

- Procedure** 1. Switch to the first objective and/or reflector (if available) positions of interest using the knurled rings.

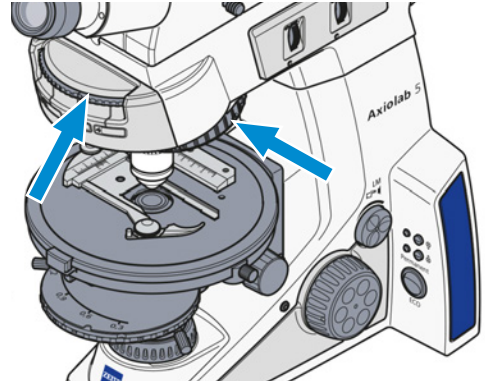

2. Set the desired light intensity by turning the **Intensity/LM knob**.

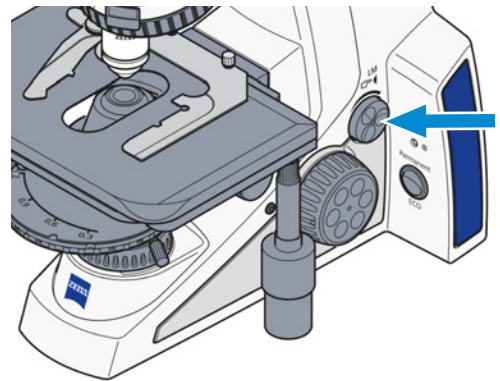

3. Press the **Intensity/LM knob** for at least 1.5 seconds.
 → The light intensity for this objective/reflector combination is saved.
 → When using LED as light source, the LED is switched off for 300 ms. This is visible through the eyepieces and serves as an indicator for the user.
4. Switch to the second objective/reflector position.
5. Press the **Intensity/LM knob** for at least 1.5 seconds.
 → Now a ratio between the first and the second objective/reflector combinations is established.
6. Repeat the procedure to set the light intensity ratios for further objective/reflector combinations.
- ↳ The light intensities for all set objective/reflector combinations are stored.
 ↳ After switching on the microscope, the previous setting of the Light Manager will be restored

5.3.5 Setting the ECO/Permanent Mode

- Prerequisite** ✓ The microscope is operational.

- Procedure** 1. Select the ECO or Permanent mode for microscope illumination using the **ECO/Permanent mode switch**.

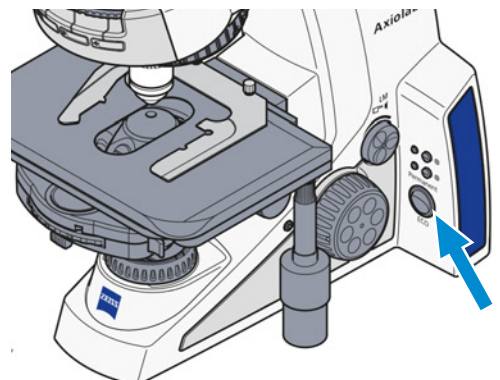

5.4 Setting Up for Transmitted Light Techniques

5.4.1 Setting Up for Transmitted Light Brightfield Microscopy

- High-contrast sample slide

The equipment of every microscope stand model enables the use of transmitted light brightfield microscopy. All available condensers (except special condensers such as darkfield condensers) can be used for transmitted light brightfield microscopy.

- Prerequisite**
- ✓ The microscope is operational.
 - ✓ The microscope is *adapted* [▶ 59] to the user.
 - ✓ The height stop of the condenser carrier is *adjusted* [▶ 60].

- Procedure**
1. If required, push the **TL button** for transmitted light illumination.

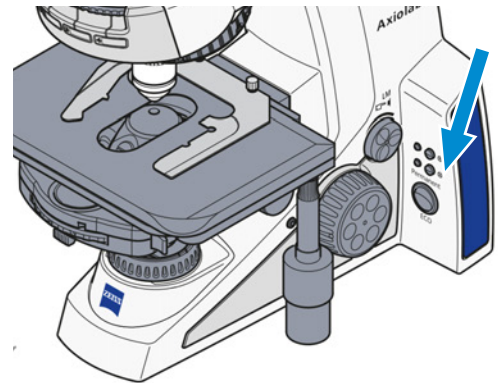

2. Adjust the image brightness using the **Intensity/LM knob** on the microscope stand.

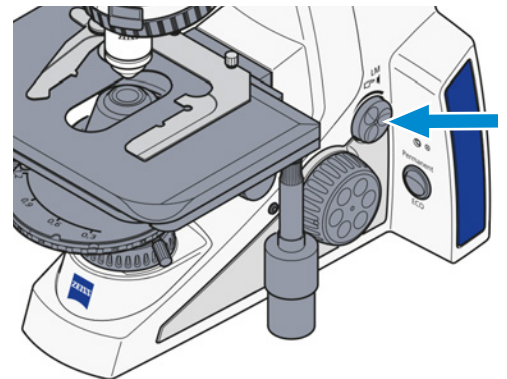

3. Insert the high-contrast sample into the sample holder of the stage.
4. Set position H (or B = brightfield), when using condensers with a turret/modulator disk and knurled ring.

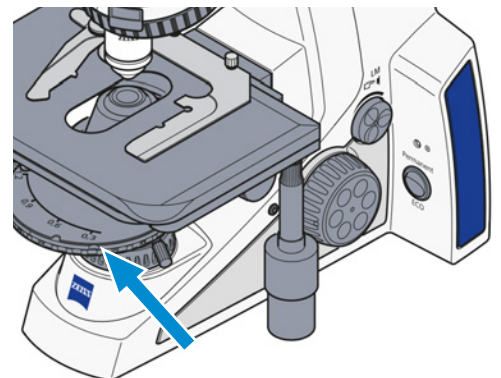

- Swivel the front lens into the beam path with $\geq 10\times$ objectives, if condensers with a swiveling front lens are used.

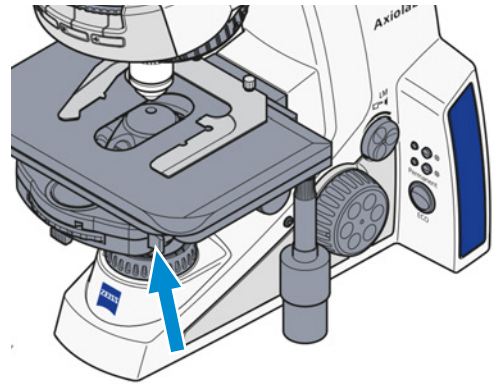

- Set the condenser with the knurled knob for vertical adjustment to the upper stop.

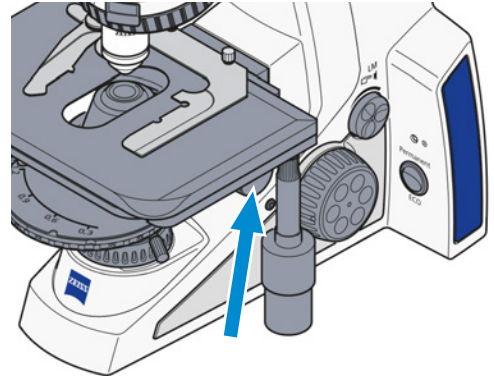

- Swivel in the 10x objective on the nosepiece.

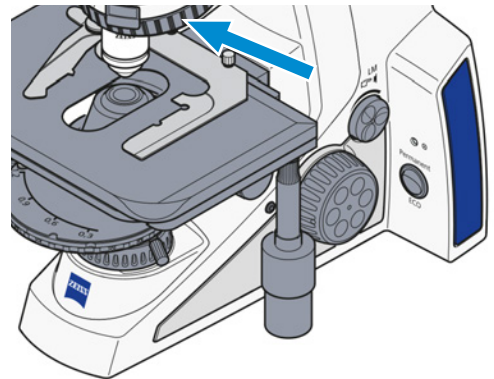

- Focus the sample.

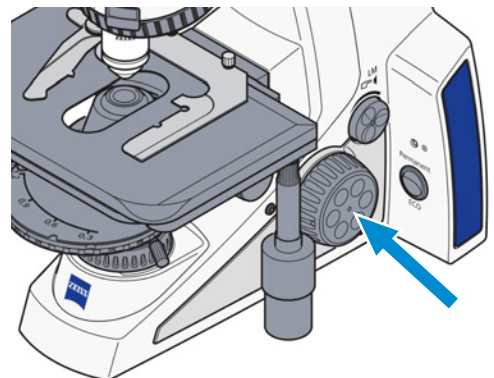

9. Close the luminous-field diaphragm until it is visible (even if not in focus) in the field of view

A

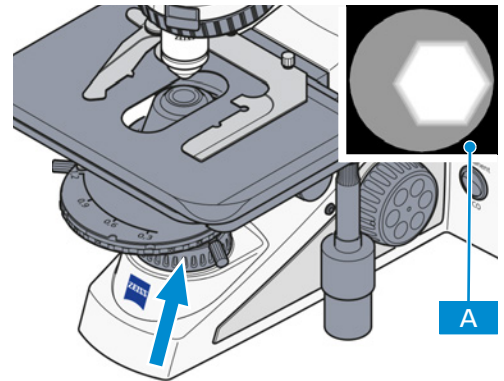

10. Turn the knurled knob for vertical adjustment to lower the condenser until the edge of the luminous-field diaphragm appears in focus

B

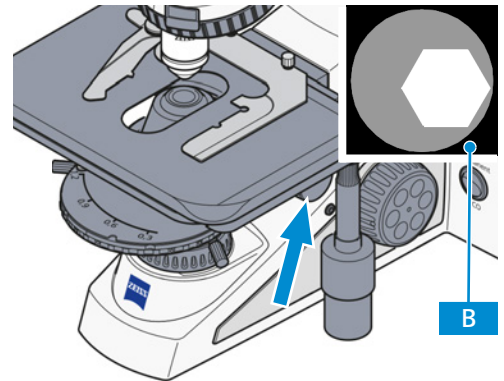

11. Center the luminous-field diaphragm using the two centering screws on the condenser carrier

C

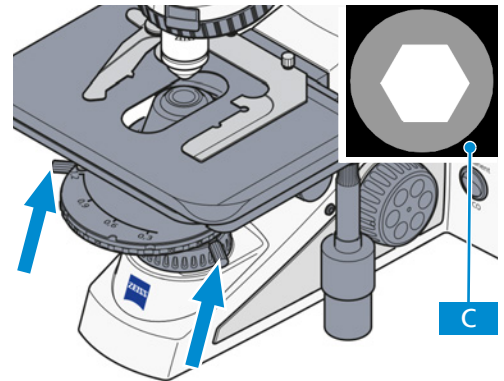

12. Open the luminous-field diaphragm until the edge of the diaphragm just disappears from the field of vision

D

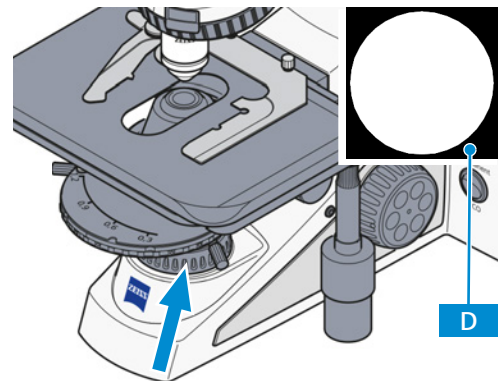

13. Remove an eyepiece from the binocular tube to adjust the aperture diaphragm (contrast).
14. Look into the tube with the naked eye.

15. Set the aperture diaphragm with the adjusting lever to between $2/3$ - $4/5$ of the diameter of the exit pupil of the objective **E**.

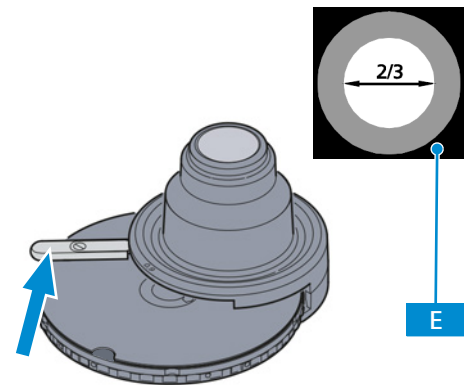

→ In most applications, this aperture diaphragm setting provides optimal contrast at almost ideal resolution, and is therefore the best compromise for the human eye.

16. Reinsert the eyepiece into the binocular tube.

17. Remove the high-contrast sample.

↳ The illumination is now adjusted according to the KÖHLER method.

Info

Every change of objective will result in a change in sample field size and objective aperture, together with a possible slight change in centering, so that for optimal results the luminous-field and aperture diaphragm adjustments must be repeated.

With objectives $< 10\times$, the front lens of the condenser (if swivelable) must be swivelled out of the beam path and the aperture diaphragm completely opened. For better contrast with such large object fields, the luminous-field aperture should be closed to a certain extent. Overclosing should be avoided so as not to impair the uniformity of the illumination of the field of view.

5.4.2 Setting Up for Transmitted Light Darkfield Microscopy

- Prerequisite**
- ✓ The microscope is operational.
 - ✓ The height stop of the condenser carrier is *adjusted* [▶ 60].
 - ✓ A suitable condenser for transmitted light darkfield microscopy is *installed* [▶ 52].
 - ✓ The illumination is adjusted for *transmitted light brightfield microscopy* [▶ 63].

- Procedure**
1. Set the modulator disk to position D (or DF = darkfield).

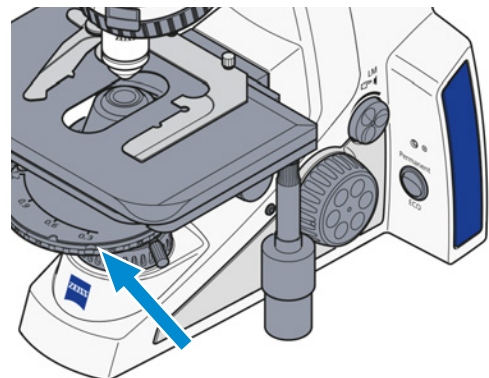

2. Turn the knurled knob for vertical adjustment of the condenser to the upper stop.

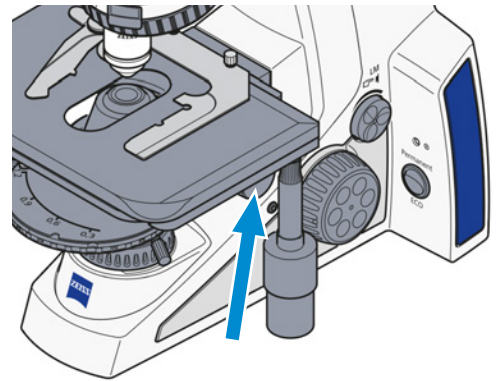

3. Swivel the objective with the highest possible aperture into position on the nosepiece.

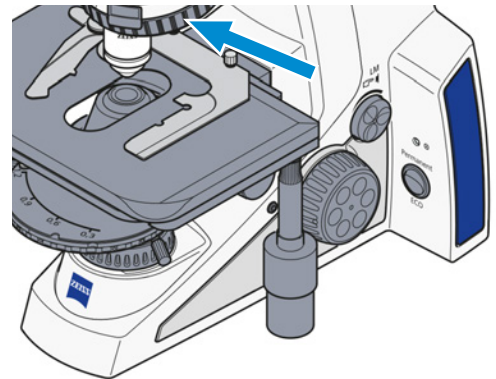

4. Place the sample on the stage.
5. Focus the sample.

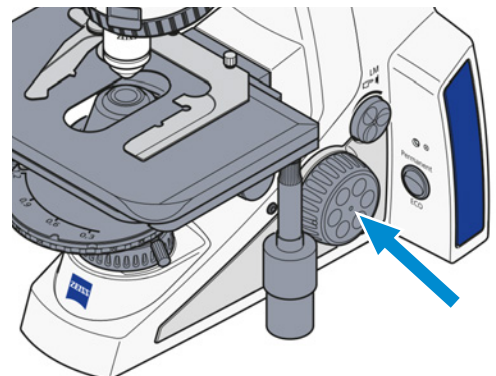

6. Close the luminous-field diaphragm enough to make it visible in the field of view (even if blurred).

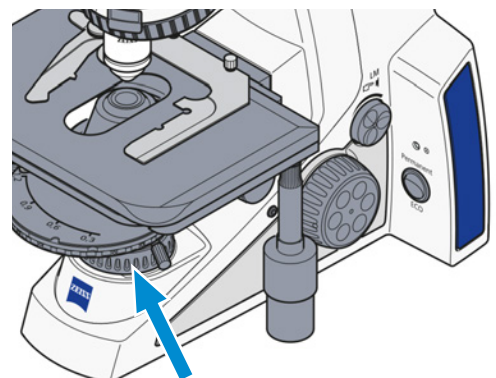

7. Lower the condenser until the edge of the field diaphragm appears sharp using the knurled knob for vertical adjustment.

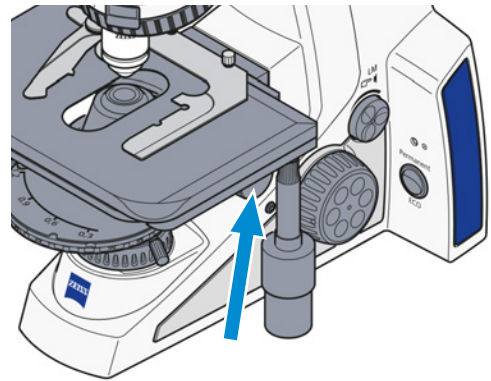

8. Center the luminous-field diaphragm on the condenser carrier using the adjustment screws.

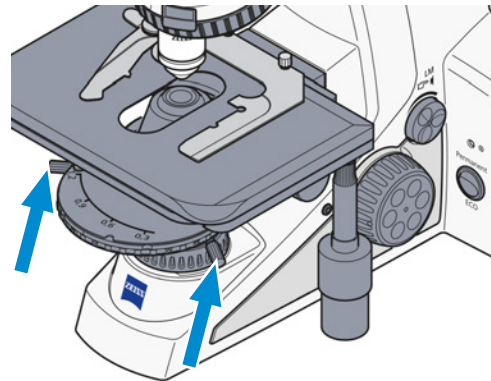

9. Open the luminous-field diaphragm enough to make the edge of the diaphragm disappear from the field of view.
 10. Remove one eyepiece or replace it with the auxiliary microscope.
 11. Check the centering of the darkfield diaphragm in the objective exit pupil.
 - The objective exit pupil must appear homogeneously dark.
 12. If necessary, *center* [▶ 125] the darkfield diaphragm.
 13. if required, remove the auxiliary microscope.
 14. Insert the eyepiece.
 15. Adjust the condenser height using the knurled knob for vertical adjustment until no more lighter areas are visible in the field of view .
 16. Adjust the luminous-field diaphragm diameter to the size of the field of view.
- ↳ The illumination is now adjusted for transmitted light darkfield.

Info

Darkfield microscopy requires samples to be considerably cleaner than in other techniques. In particular, fingerprints, dirt or dust particles have a negative effect, as they brighten the background of the field of view and decrease the contrast of the object image.

5.4.3 Setting Up for Transmitted Light Phase Contrast Microscopy

- Prerequisite**
- ✓ The microscope is operational.
 - ✓ Phase contrast objectives with the phase rings **PhC 1**, **PhC 2** or **PhC 3** are *installed* [▶ 51].
 - ✓ Condenser with modulator disk with centerable ring diaphragms **PhC 1**, **PhC 2** and **PhC 3** is *installed* [▶ 55].

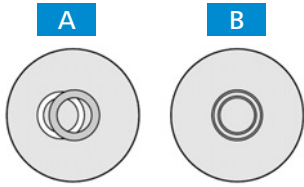
- Procedure**
1. Swivel the phase contrast objective into the beam path (e.g. **Ph1**).
 2. Switch on the annular phase diaphragm on the condenser's revolver disk with the same labeling as the objective (e.g. **Ph1**)
 3. *Replace one eyepiece* [▶ 50] with an auxiliary microscope.
 4. With the adjusting fixture on the auxiliary microscope, focus the annular phase diaphragm and the phase ring in the objective exit pupil.
 5. Check the centering and the overlap of the lighter annular phase diaphragm (in the condenser) with the darker phase ring (in the objective). Both rings must be centered and overlapping **B**.
- 
6. If the overlap is not exact **A**, *recenter the lighter annular phase diaphragm* [▶ 125].
 7. Remove the auxiliary microscope and replace the eyepiece.

Info

To increase the image contrast, a green 32 x 4 interference broadband filter can be mounted on the field diaphragm or inserted into the color glass carrier (if available).

5.4.4 Setting Up for Transmitted Light Polarization

Polarization methods can be used in the transmitted light on the following microscope types:

- Axiolab 5 Pol-TL (430037-9130-000)
- Axiolab 5 Pol-TL/conoscopy (430037-9042-000)
- Axiolab 5 Pol-TL/RL (430037-9032-000)

The following requirements must be fulfilled:

- The microscope is operational.
- Strain-free objectives are installed in the *nosepiece* [▶ 51].
- The rotary stage is *installed* [▶ 114].
- A polarizer D (fixed or rotatable) is *installed* [▶ 122].
- Analyzer slider D, fixed, or lambda compensator or lambda/4 compensator is available.
- A depolarizer for avoiding unwanted polarizing effects is installed in the tube.
- The microscope is adjusted for *transmitted light brightfield microscopy* [▶ 63].
- The rotary stage is *centered* [▶ 115].
- The objectives are *centered* [▶ 116].

5.4.4.1 Detecting Birefringence

For more information about the method, see chapter *Detecting Birefringence* [▶ 41].

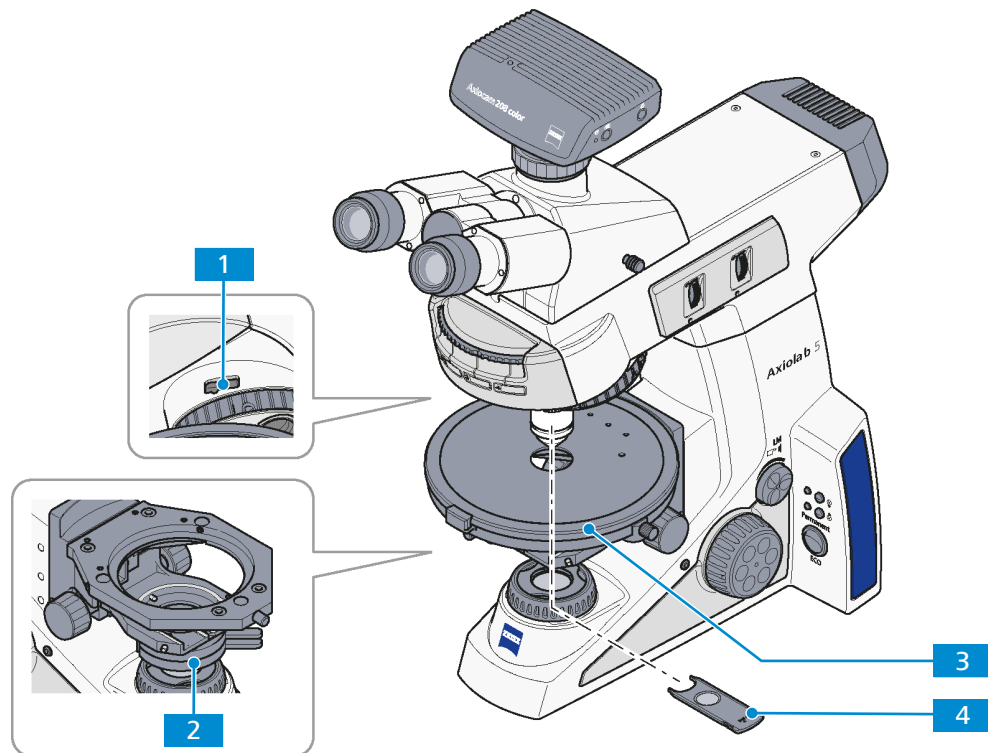

- | | |
|--|--------------------|
| 1 Slit for analyzer/compensator | 2 Polarizer |
| 3 Rotary stage | 4 Analyzer |

- Procedure**
- Swing the polarizer **2** into the beam path.
 - When using a rotatable polarizer, position it to 0°.
 - Put the analyzer **4** into the slit for the compensator **1**.
→ The field of view appears dark.
 - Bring the sample into the field of view.
 - With the rotary stage **3**, turn the sample.
→ Normally, birefringent (anisotropic) objects will now show the interference color and intensity variations during rotation between crossed polarizers. Optically anisotropic substances may remain dark when an isotropic direction, e.g. from optically single-axle or double-axle crystals, is oriented parallel to the observation direction.

5.4.4.2 Determination of the Polarization Direction

For more information about the method, see chapter *Determination of the Polarization Direction* [▶ 41].

Prerequisite ✓ An eyepiece with cross hair reticle is *installed* [▶ 50].

✓ The Pol adjustment sample for polarization microscopy is available.

- Procedure**
1. Swing the polarizer into the beam path.
 2. When using a rotatable polarizer, position it to 0°.
 3. Put the analyzer into the slit for the compensator or swing analyzer module on the reflector turret/slider.
 - The field of view appears dark.
 4. Place the Pol adjustment sample on the microscope.
 5. Turn the rotary stage until the adjustment sample appears dark.
 6. Remove the analyzer from the beam path.
 7. Align the reticle of the eyepiece along the split cracks of the adjusting sample.
 8. Return the analyzer into the beam path.
 9. Remove the adjustment sample.
 - The forward direction of the polarizer and analyzer is parallel to the cross hair in the reticle (polarizer east-west, analyzer north-south).
 10. Turn the rotary stage with the sample, e.g. a synthetic fiber, until the sample reaches maximal darkness.
 - The fiber is parallel to one of the two lines in the cross hair orientation.
 11. Turn the rotary stage by approx. 45° until the longitudinal axis of the fiber is pointing in northeast-southwest direction.
 - The sample shows the strongest brightness (diagonal position). It can have any color in this position.
 12. Slide in the lambda compensator (possible only if used with screw-in analyzer in tube or intermediate plate).
 - The sample changes its color depending on its orientation (northeast-southwest or northwest-southeast).

5.4.4.3 Measuring Path Differences

For more information about the method, see *Measuring Path Differences* [▶ 43].

Prerequisite ✓ The correct inter-pupillary distance in the binocular tube is set.

- Procedure**
1. Accurately position the sample to be examined on the center of the eyepiece reticle.
 2. Limit the aperture to a value of about 0.2.
 3. Turn the rotary stage until the sample is almost extinguished, i.e. **completely dark**, and set the 45° locking position.
 4. Rotate the stage **once** (by 45°) so that the sample is in a diagonal position (sample becomes bright).
 5. *Determine* [▶ 43] the suitable compensator.
 6. Insert the determined compensator into the slot as far as it will go.
 7. Use the enclosed operating instructions for measurement preparation and measurement procedure.

5.4.4.4 Circular Polarization Contrast

For more information about the method, see *Circular Polarization Contrast* [▶ 43].

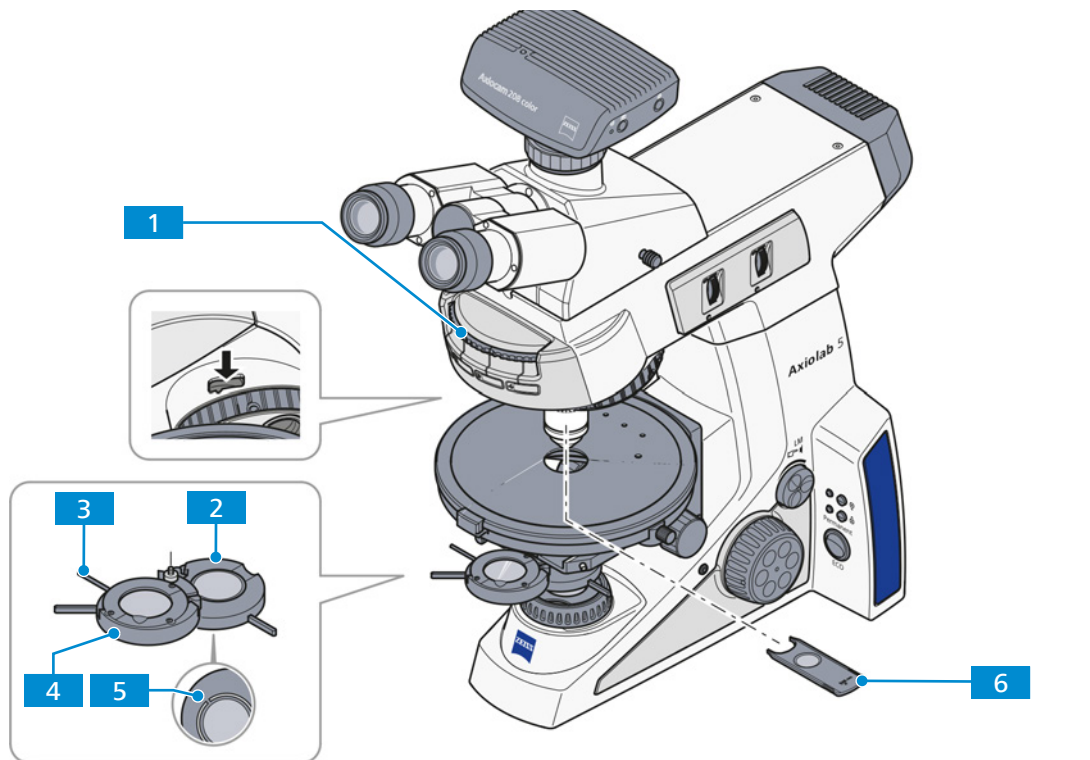

- | | |
|--|---|
| 1 Reflector turret | 2 Lower part of circular polarizer |
| 3 Lever for rotating the lambda/4 plate | 4 Lambda/4 plate in the upper part of the circular polarizer |
| 5 Adjustment slit | 6 Lambda/4 compensator (6x20) |

- Prerequisite**
- ✓ The circular polarizer D including the corresponding lambda/4 plate is installed.
 - ✓ The analyzer module is installed in the reflector turret or the stand is equipped with the intermediate plate for analyzer slider and the analyzer slider is available.
 - ✓ The lambda/4 compensator (6x20) is available.

- Procedure**
1. Remove the sample.
 - Initially do not use a sample for the further settings.
 2. Swivel the lower part **2** of the circular polarizer into the light path up to the click stop.
 3. Swing in the analyzer module on the reflector turret **1** or insert the analyzer slider into the intermediate plate.
 4. At full light intensity, assess the extinction (darkening) of the field of view without sample.
 5. Push the lambda/4 compensator **6** into the compensator slot above the nosepiece as far as it will go.
 6. Swivel the upper part **4** of the circular polarizer into the light path.
 7. Rotate the lever of the lambda/4 plate **3** of the D circular polarizer until the field of view appears dark gray.
 - The lever points 45° to the right.
 - The maximum extinction is obtained.

8. Place the sample to be examined on the stage.
 - The samples appear constantly and independently of the stage rotation in their specific interference color, which depends on the material, sample thickness and orientation.
9. For the detection of gout or pseudo-gout, select crystal needles that are oriented in the gamma direction (see marking on the lambda plate).
 - If the crystal needles oriented parallel to the gamma direction of the lambda plate are yellow, and the crystal needles lying at a right angle to the gamma direction are blue, the crystals are monosodium urate crystals (gout).
 - If the crystal needles oriented parallel to the gamma direction of the lambda plate are blue, and the crystal needles lying at a right angle to the gamma direction are yellow, the crystals are calcium pyrophosphate crystals (pseudo-gout).

5.4.4.5 Transmitted Light Polarization with the Conoscopy Stand

The present section applies to the following microscope type:

- Axiolab 5 Pol-TL/conoscopy (430037-9042-000)

NOTICE

Risk of mechanical damage

The movements of **rotary knobs A** and **BL** and the respective setting wheels are coupled with each other. Only one control element should therefore be operated at a time and the movement of the other should not be inhibited or blocked. Otherwise, mechanical damage may occur.

- ▶ Operate only one of the 4 controls (rotary knobs, setting wheels) at a time.

Info

If the **rotary knob BL** is set to the **On** position, **rotary knob A** is automatically moved into the **On** position if it is not there already. If, on the other hand, **rotary knob A** is set to the **Off** position, **rotary knob BL** is automatically moved into the **Off** position if it is not there already.

5.4.4.5.1 Detecting Birefringence

For more information about the method, see chapter *Detecting Birefringence* [▶ 41].

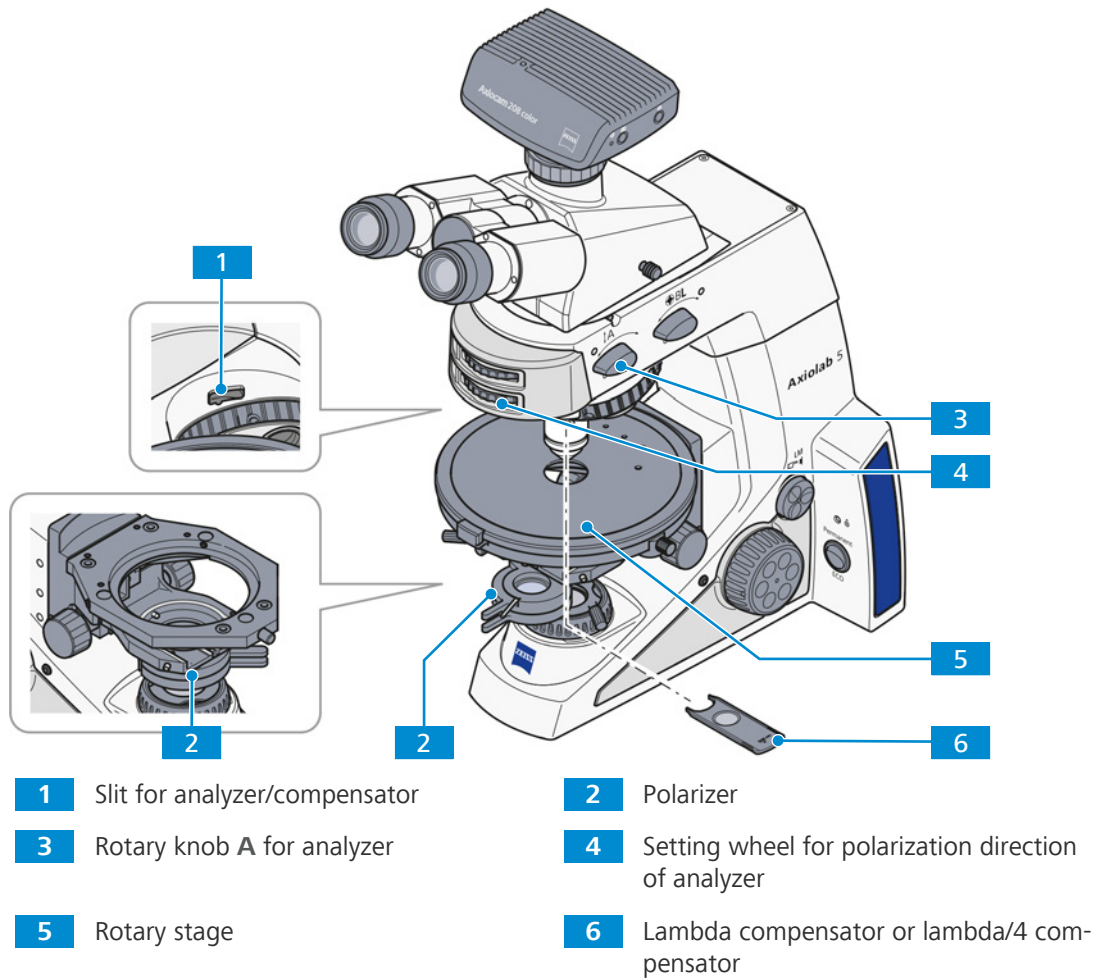

- Prerequisite**
- ✓ The illumination is adjusted for *transmitted light brightfield microscopy* [▶ 63] using the KÖHLER method.
 - ✓ Lambda compensator or lambda/4 compensator is available.

- Procedure**
1. Swing the polarizer **2** into the beam path.
 2. When using a rotatable polarizer, position it to 0°.
 3. Swivel the analyzer into the beam path (on position) with rotary knob **A 3**.
 4. Adjust the analyzer using the setting wheel **4** until the field of view is dark.
 5. Bring the sample into the field of view.
 6. With the rotary stage **5**, turn the sample.
 - Normally, birefringent (anisotropic) objects will now show the interference color and intensity variations during rotation between crossed polarizers. Optically anisotropic substances may remain dark when an isotropic direction, e.g. from optically single-axis or double-axis crystals, is oriented parallel to the observation direction.
 7. If required, put the lambda compensator or lambda/4 compensator **6** into the slit for the compensator **1** for detecting birefringence.

5.4.4.5.2 Determination of the Polarization Direction

For more information about the method, see chapter *Determination of the Polarization Direction* [▶ 41].

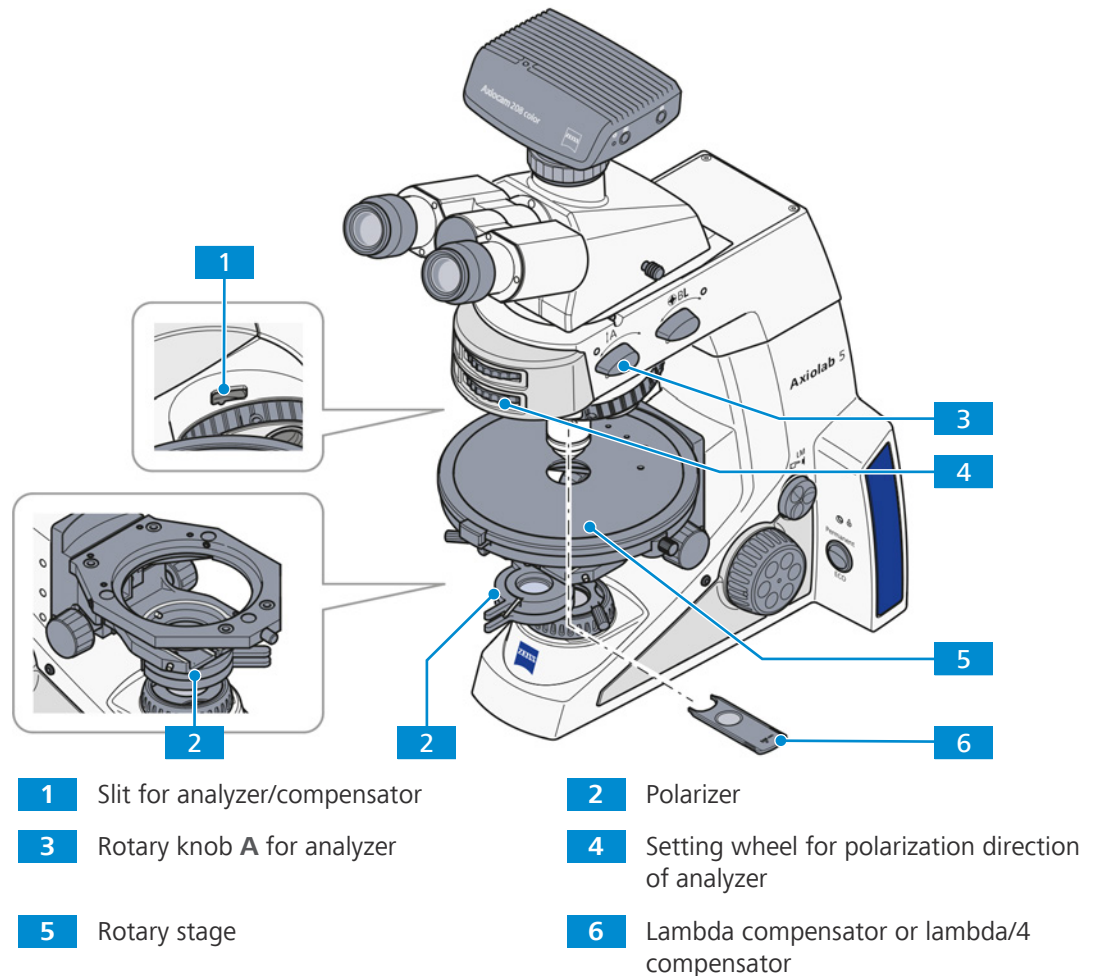

- Prerequisite**
- ✓ An eyepiece with cross hair reticle is *installed* [▶ 50].
 - ✓ The Lambda or lambda/4 compensator are available.
 - ✓ The Pol adjustment sample for polarization microscopy is available.

- Procedure**
1. Swing the polarizer **2** into the beam path.
 2. When using a rotatable polarizer, position it to 0°.
 3. Swivel the analyzer into the beam path (on position) with rotary knob **A** **3**.
 4. Adjust it using the setting wheel **4** until the field of view is dark.
 5. Place the Pol adjustment sample on the microscope.
 6. Turn the rotary stage **5** until the adjustment sample appears dark.
 7. Swivel out the analyzer **3**.
 8. Align the reticle of the eyepiece along the split cracks of the adjusting sample.
 9. Return the analyzer **3** into the beam path.
 10. Remove the adjustment sample.
 - The forward direction of the polarizer and analyzer is parallel to the cross hair in the reticle (polarizer east-west, analyzer north-south).
 11. Turn the rotary stage with the sample, e.g. a synthetic fiber, until the sample reaches maximal darkness.
 - The fiber is parallel to one of the two lines in the cross hair orientation.

12. Turn the rotary stage by approx. 45° until the longitudinal axis of the fiber is pointing in northeast-southwest direction.
 - The sample shows the strongest brightness (diagonal position). It can have any color in this position.
13. Slide in the lambda compensator or lambda/4 compensator **6** in the slit **1**.
 - The sample changes its color depending on its orientation (northeast-southwest or northwest-southeast).

5.4.4.5.3 Measuring Path Differences

For more information about the method, see *Measuring Path Differences* [▶ 43].

- Prerequisite**
- ✓ The illumination is adjusted for *transmitted light brightfield microscopy* [▶ 63].
 - ✓ The correct *inter-pupillary distance* [▶ 59] in the binocular tube is set.

- Procedure**
1. Accurately position the sample to be examined on the center of the eyepiece reticle.
 2. Limit the aperture to a value of about 0.2.
 3. Turn the rotary stage until the sample is almost extinguished, i.e. **completely dark**, and set the 45° locking position.
 4. Rotate the stage **once** (by 45°) so that the sample is in a diagonal position (sample becomes bright).
 5. *Determine* [▶ 43] the suitable compensator.
 6. Insert the determined compensator into the slot as far as it will go.
 7. Use the enclosed operating instructions for measurement preparation and measurement procedure.

5.4.4.5.4 Determining the Optical Character of Crystals

For more information about the method, see chapter *Determining the Optical Character of Crystals* [▶ 44].

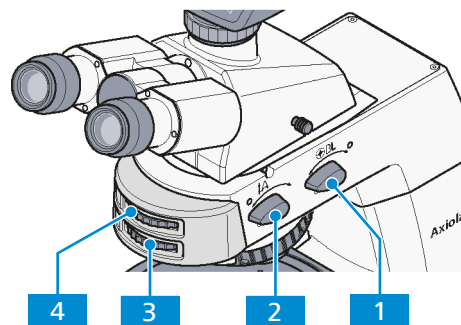

- | | |
|---|--|
| 1 Rotary knob BL for Bertrand lens | 2 Rotary knob A for analyzer |
| 3 Setting wheel for polarization direction of analyzer | 4 Setting wheel for focusing of Bertrand lens |

- Prerequisite**
- ✓ A strain-free objective is screwed in, recommended:
 - N-Achroplan 50x/0.8 Pol objective or
 - EC Plan-Neofluar 40x/0.9 Pol objective
 - ✓ A suitable condenser 0.9 Pol is installed.
 - ✓ The illumination is adjusted for *transmitted light brightfield microscopy* [▶ 63].

- Procedure**
1. Place the sample on the stage.
 2. Focus the sample.
 3. Swivel the analyzer into the beam path (on position) with rotary knob **A** **2**.

4. If necessary, change the polarization direction of the analyzer using the setting wheel **3**.
5. Place a selected crystal in the center of the crossline reticle.
6. Swivel in the N-Achroplan 50x/0.8 Pol objective or EC Plan-Neofluar 40x/0.9 Pol objective and focus using the focusing drive.
7. If necessary, close the luminous-field aperture to avoid superimposition of axial figures of neighboring crystals on the axial figure to be examined.
→ The smallest crystal value that can be faded out is 170 μm .
8. If necessary, switch on Bertrand lens **BL 1**.
→ The axial figure will appear in the field of view.
9. Bring the axial figure into focus using the setting wheel **4**.
10. Determine the optical character of the crystal.

5.4.4.5.5 Circular Polarization Contrast

For more information about the method, see *Circular Polarization Contrast* [[▶ 43](#)].

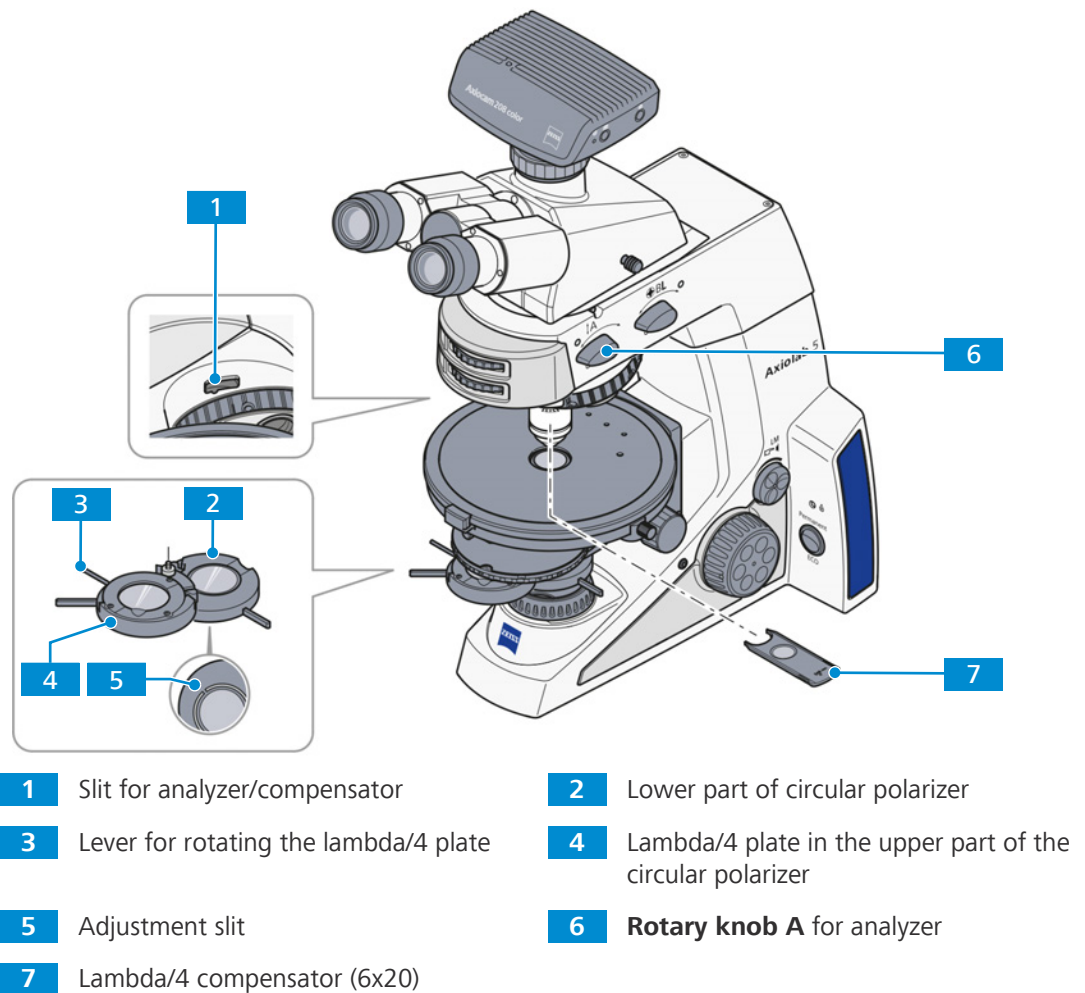

- Prerequisite**
- ✓ A strain-free objective is screwed in, recommended:
 - N-Achroplan 50x/0.8 Pol objective or
 - EC Plan-Neofluar 40x/0.9 Pol objective
 - ✓ The circular polarizer D including the corresponding lambda/4 plate is installed.
 - ✓ The lambda/4 compensator (6x20) is available.
 - ✓ The illumination is adjusted for *transmitted light brightfield microscopy* [[▶ 63](#)].

- Procedure**
1. Remove the sample.
 - Initially do not use a sample for the further settings.
 2. Swivel the analyzer with **rotary knob A** **6** into the beam path.
 3. Swivel the lower part **2** of the circular polarizer into the light path up to the click stop.
 4. At full light intensity, assess the extinction (darkening) of the field of view without sample.
 5. If this is not optimal, align the analyzer as necessary.
 6. Push the lambda/4 compensator **7** into the compensator slit **1** above the nosepiece as far as it will go.
 7. Swivel the upper part **4** of the circular polarizer into the light path.
 8. Rotate the lever of the lambda/4 plate **3** of the circular polarizer until the field of view appears dark gray.
 - The lever points 45° to the right.
 - The maximum extinction is obtained.
 9. Place the sample to be examined on the stage.
 - The samples appear constantly and independently of the stage rotation in their specific interference color, which depends on the material, sample thickness and orientation.
 10. For the detection of gout or pseudo-gout, select crystal needles that are oriented in the gamma direction (see marking on the lambda plate).
 - If the crystal needles oriented parallel to the gamma direction of the lambda plate are yellow, and the crystal needles lying at a right angle to the gamma direction are blue, the crystals are monosodium urate crystals (gout).
 - If the crystal needles oriented parallel to the gamma direction of the lambda plate are blue, and the crystal needles lying at a right angle to the gamma direction are yellow, the crystals are calcium pyrophosphate crystals (pseudo-gout).

5.5 Setting Up for Reflected Light Techniques

5.5.1 Setting Up for Reflected Light Brightfield Microscopy

For more information about the method, see chapter *Reflected Light Brightfield Microscopy Using the KÖHLER Method* [▶ 45].

- Prerequisite**
- ✓ A light source for reflected light is available on the stand.
 - ✓ In the reflector turret, an ACR P&C brightfield reflector module for reflected light is installed.
 - ✓ The microscope is *adapted* [▶ 59] to the user.
 - ✓ The microscope is operational.

- Procedure**
1. If required, push the **RL button** for reflected light illumination.

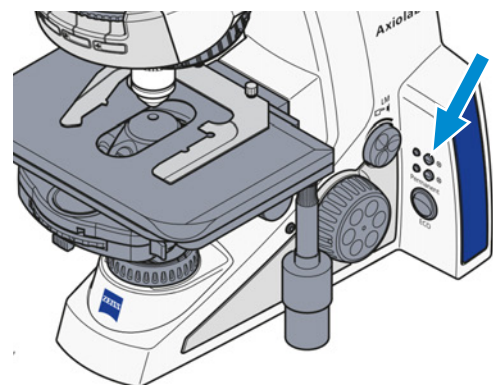

2. Adjust the image brightness using the **Intensity/LM knob** on the microscope stand.

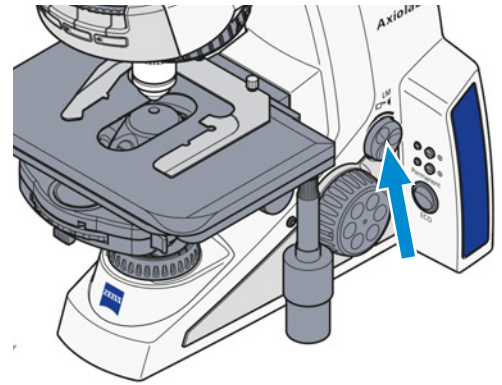

3. Place a high-contrast reflected light sample into the sample holder of the mechanical stage.
4. Swivel the 10x objective into the beam path.

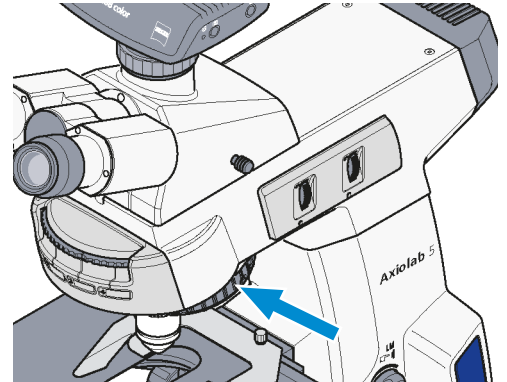

5. Swivel in the position with the brightfield reflector module on the reflector turret.

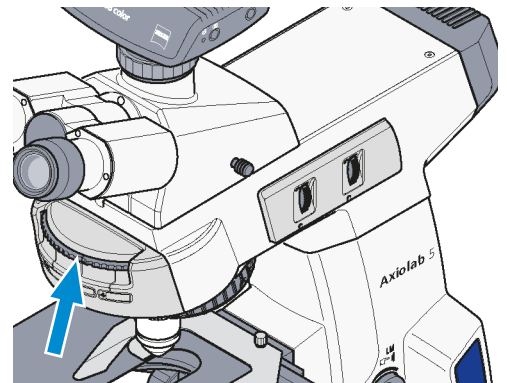

6. Focus the sample.
Try to focus away from the sample to avoid any collision between the objective and sample.

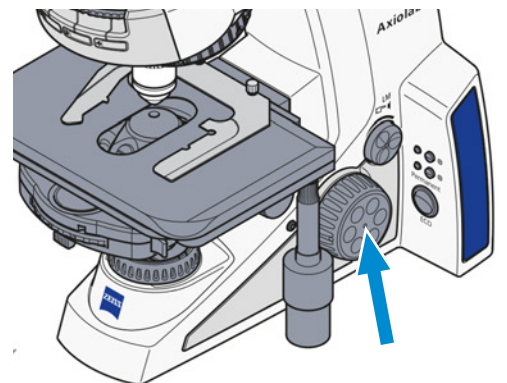

7. Set the knurled wheel of the aperture diaphragm **A** to a medium position.

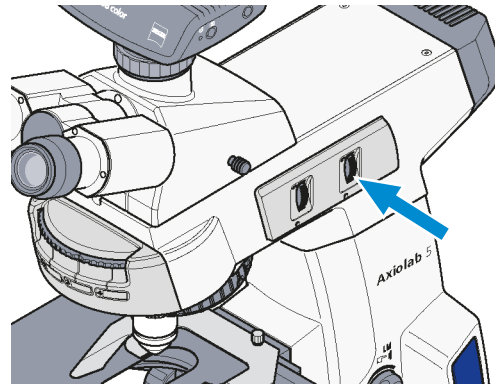

8. Adjust the knurled wheel of the luminous-field diaphragm **F** so that the field diaphragm becomes visible in the field of view.

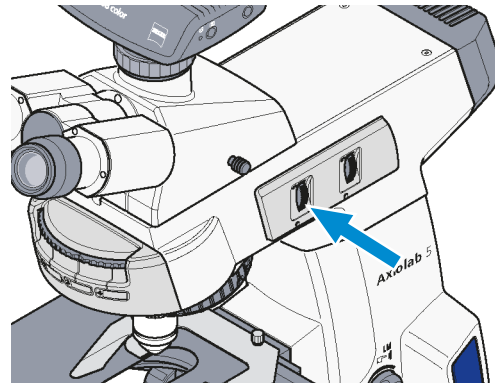

9. Focus on the edge of the luminous-field diaphragm using the focusing drive.

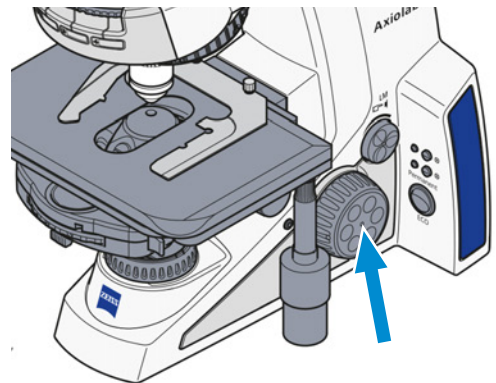

10. Open the luminous-field diaphragm enough to make the edge of the diaphragm disappear from the field of view.

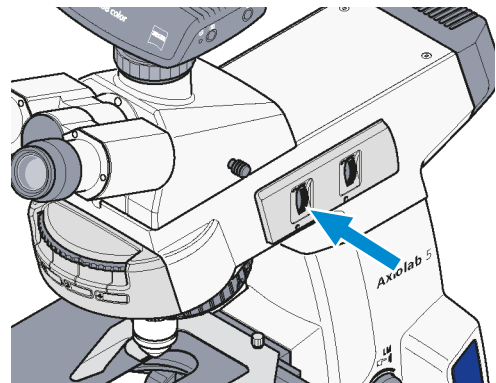

11. Remove an eyepiece from the binocular tube to adjust the aperture diaphragm (contrast).
12. Look into the tube with the naked eye or use the auxiliary microscope instead of the eyepiece..

13. Set the aperture diaphragm with the knurled wheel to between $2/3$ and $4/5$ of the exit pupil diameter of the objective.
In most cases this aperture gives the best contrast at almost full resolution and is thus the best compromise for the human eye.

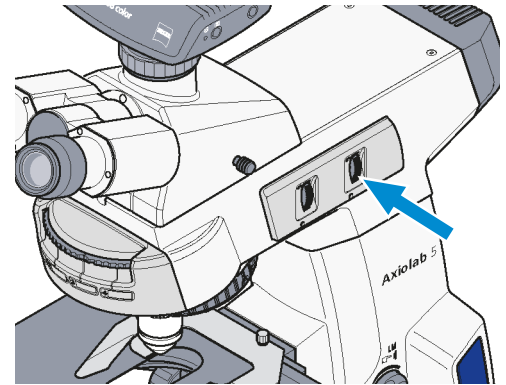

14. Replace the eyepiece.
 15. Remove the high-contrast reflected light sample.
 16. Re-adjust the focus using the coarse and fine focusing drives and set the image brightness according to the reflected light sample.
 17. Readjust the aperture diaphragm diameter after each objective change.
- ↳ The illumination is now adjusted according to the KÖHLER method.

Info

Never use the aperture diaphragm for controlling image brightness. Use the **Intensity/LM knob** for illumination intensity!

5.5.2 Setting Up for Reflected Light Darkfield Microscopy

For more information about the method, see chapter *Reflected Light Darkfield Microscopy Using the KÖHLER Method* [▶ 46].

- Prerequisite**
- ✓ A light source for reflected light is available on the stand.
 - ✓ In the reflector turret, an ACR P&C brightfield reflector module for reflected light is installed.
 - ✓ A suitable objective for RL darkfield microscopy is installed.
e.g. Epiplan-Neofluar, EC Epiplan-Neofluar, Epiplan objectives with the additional designation "HD"
 - ✓ The microscope is operational.
 - ✓ The microscope is adjusted for *reflected light brightfield microscopy* [▶ 78].
 - ✓ The displayed luminous-field aperture should be located slightly beyond the edge of the field of view.

- Procedure**
1. If used, remove the 6x20 mm compensator.
 2. Swivel in the objective position with the dark-field objective (HD) on the nosepiece.

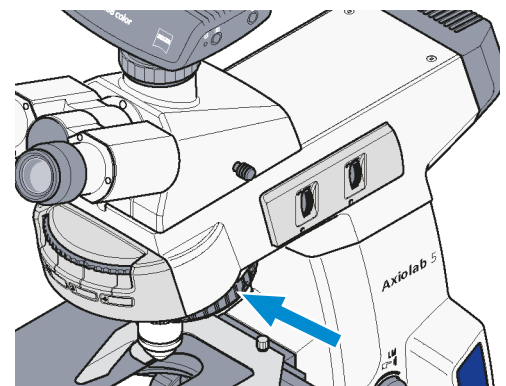

3. Swivel in the darkfield reflector module on the reflector turret.

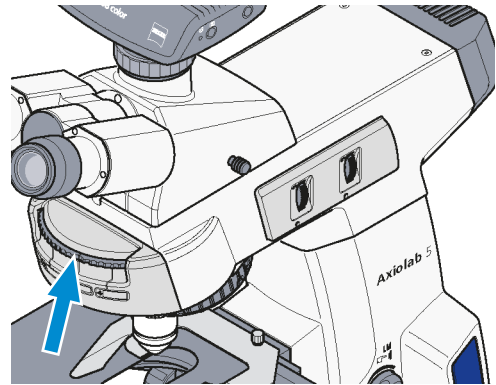

4. Completely open the aperture diaphragm A.

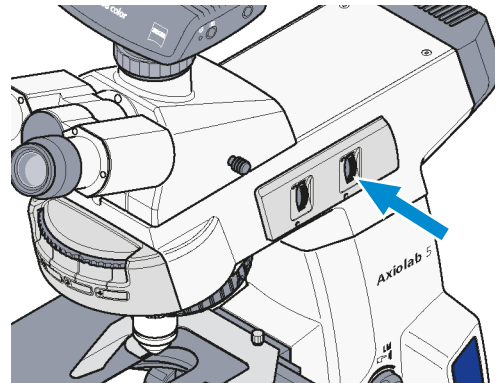

5. Switch off or remove the neutral filter as necessary.
6. Place the sample on the stage.
7. Focus the sample.

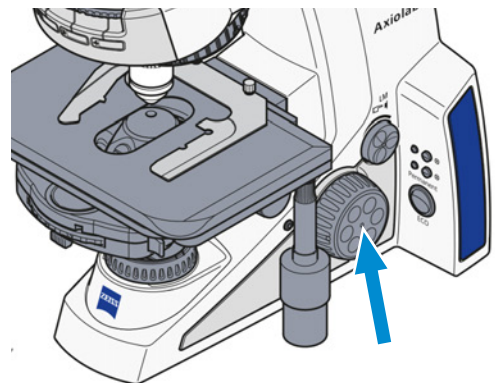

↳ The illumination is now adjusted for darkfield microscopy.

5.5.3 Setting Up for Reflected Light Polarization Microscopy

For more information about the method, see chapter *Reflected Light Polarization Microscopy* [▶ 46].

- Prerequisite**
- ✓ A light source for reflected light is available on the stand.
 - ✓ In the reflector turret, an ACR P&C DIC, C-DIC or Pol reflector module for reflected light is installed.
 - ✓ A suitable objective for RL polarization microscopy is installed.
e.g. Epiplan-Neofluar Pol, EC Epiplan-Neofluar Pol, Epiplan Pol objectives with the additional designation "HD"
 - ✓ The microscope is operational.
 - ✓ The microscope is adjusted for *reflected light brightfield microscopy* [▶ 78].
 - ✓ A analyzer slider D with lambda plate or lambda compensator or lambda/4 compensator (6x20) is available.

Procedure 1. If required, push the **RL button** for reflected light illumination.

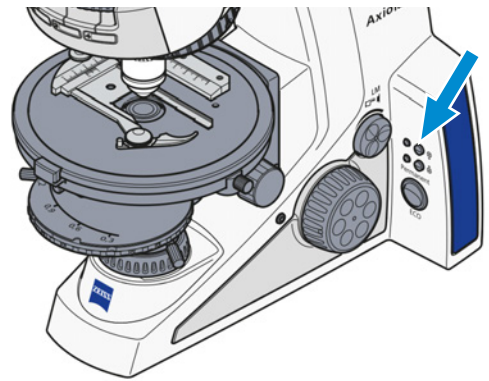

2. Swivel in the P&C (for DIC or Pol) reflector module on the reflector turret.

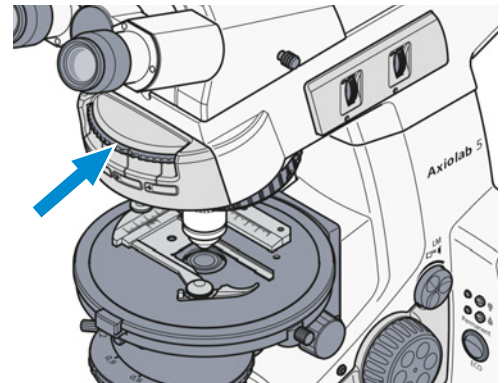

3. Insert the analyzer slider (or lambda compensator or compensator lambda/4) into the 6x20mm slot.

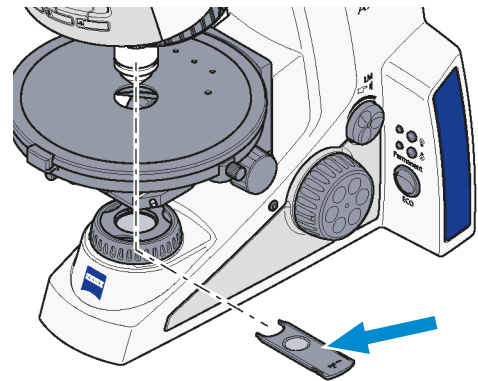

4. Place the sample on the stage.

5. Swivel in the Pol objective with the desired magnification level.

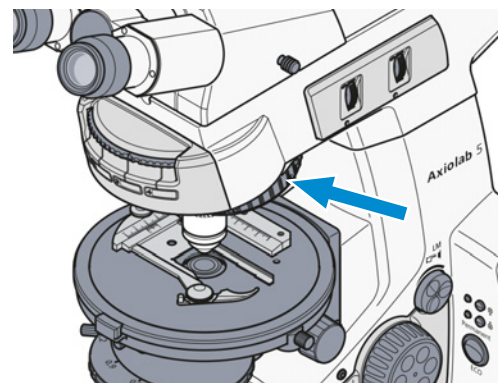

6. Focus the sample.

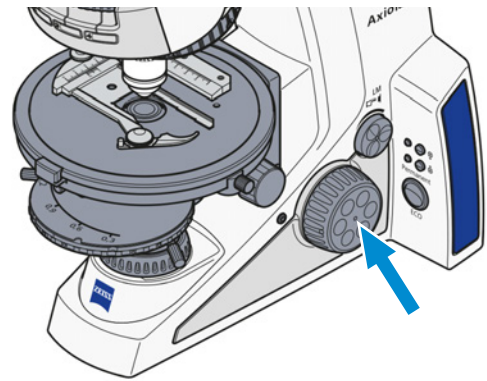

7. Observe the sample in the polarization contrast now present while turning the Pol rotary stage.

↳ The illumination is now adjusted for polarization microscopy.

5.5.4 Setting Up for Reflected Light Fluorescence Microscopy

The present section applies to the following microscope type:

- AxioLab 5 Bio-TL/FL (430037-9021-000, 430037-9120-000, 430037-9070-000)

For more information about the method, see chapter *Reflected Light Fluorescence Microscopy* [▶ 46].

WARNING

Skin or eye injury due to hazardous light emission

The light source belongs to Risk Group 3 as specified in IEC 62471 and emits LED radiation and UV radiation. Skin or eye injury can result from the exposure.

- ▶ Avoid any eye and skin exposure to the light-emitting aperture of the light source.
- ▶ Avoid exposure of skin to the radiation. Use suitable protective equipment/protective clothing if required.
- ▶ Before installing or removing the light source always make sure it is switched off.

NOTICE

Property damage due to heat emission

Microscope lamps emit a lot of heat which could damage the heat-sensitive fluorescence filters.

- ▶ Do not remove the heat protection filter when using a fluorescence filter.

Info

The adjustment of reflected light fluorescence is facilitated by starting with an objective of average magnification, e.g. EC Plan-Neofluar 20x/0.50, and a sample of high fluorescence. Demonstration samples can also be used for the start-up.

- Prerequisite**
- ✓ In the reflector turret, FL P&C reflector modules equipped with respective filter sets are installed.
 - ✓ Fluorescence protection shield is available.
 - ✓ A suitable objective for fluorescence microscopy is installed. e.g. EC Plan-Neofluar or Fluor (UV excitation)
 - ✓ The microscope is operational.
 - ✓ The microscope is adjusted for *reflected light brightfield microscopy* [▶ 78].

- Procedure**
1. Slide the fluorescence protection shield into the compensator slit above the nosepiece.

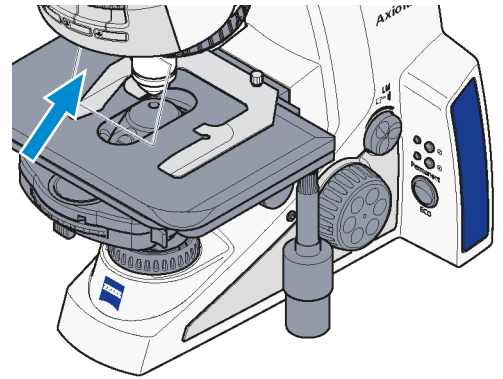

2. Swivel in the EC Plan-Neofluar objective on the nosepiece.

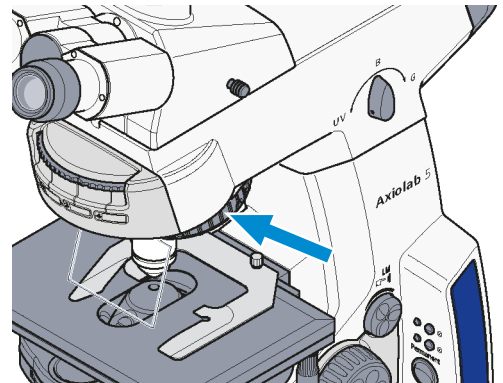

3. Initially set transmitted light illumination by pushing the **TL** button.

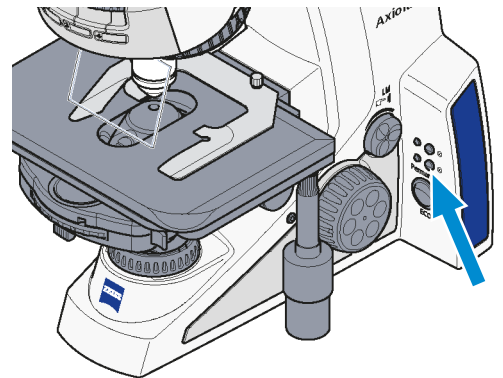

4. If necessary, turn the condenser turret to the **H** (B) position for transmitted light brightfield (or phase contrast if using a Ph objective).

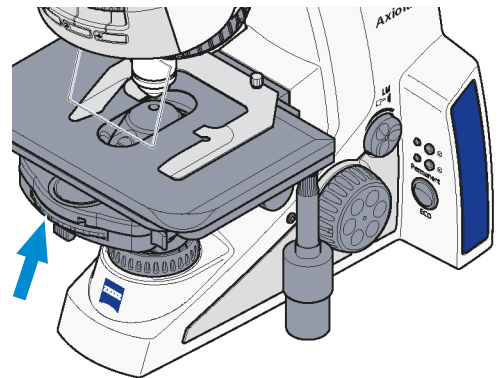

5. Seek the sample detail to be examined.

6. Adjust the light intensity by turning the **Intensity/LM knob**.

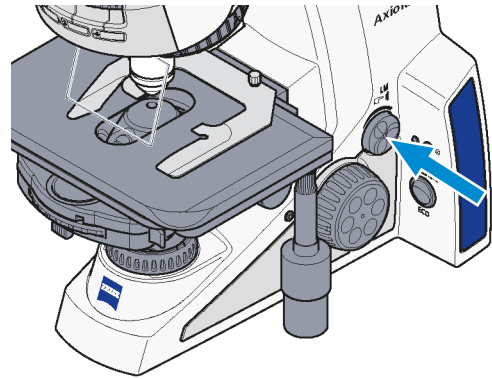

7. Focus the sample.

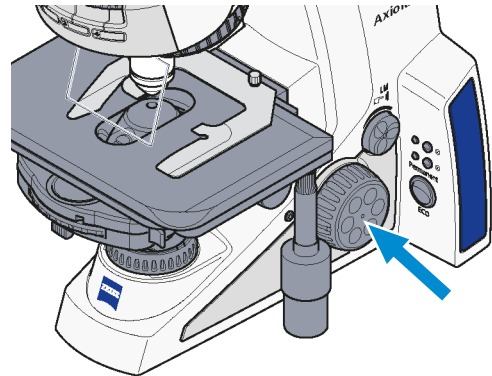

8. Swivel it in the FL P&C reflector module with the desired fluorescence filter combination (depending on the excitation mode).

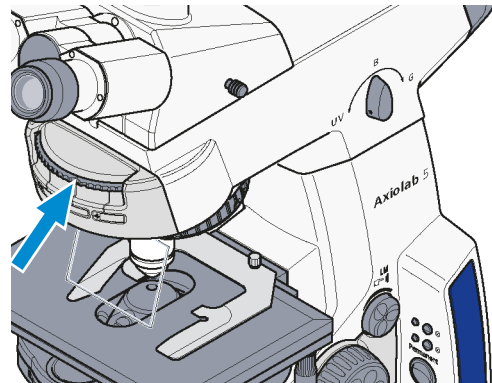

9. Swivel in the desired LED (UV, B or G) using the **LED selection knob**.

CAUTION To avoid dazzling when switching between the LEDs, the brightness should be reduced slightly beforehand.

NOTICE When switching between the three LEDs, the current brightness setting is adopted.

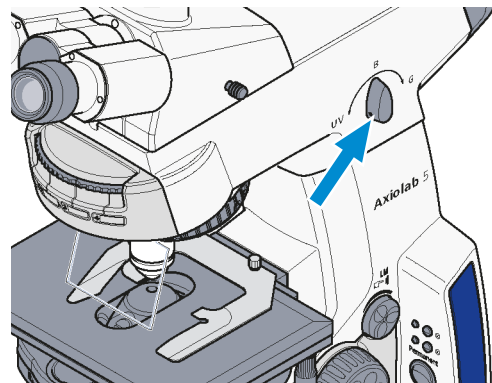

10. Set reflected light illumination by pushing the **RL button**.

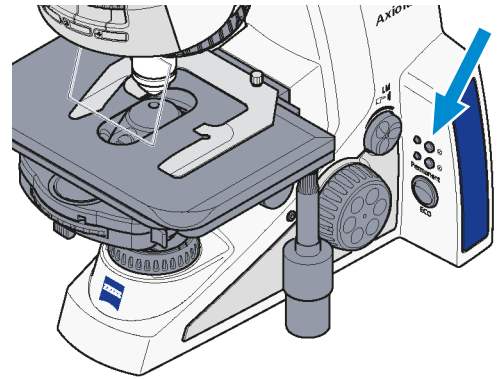

11. Adjust the light intensity for reflected light by turning the **Intensity/LM knob**.
 12. Focus the sample.
- ↳ The illumination is now adjusted for fluorescence microscopy.

5.6 Switching Off the Microscope

- Procedure**
1. Switch the microscope off using the power switch **On/Off**.

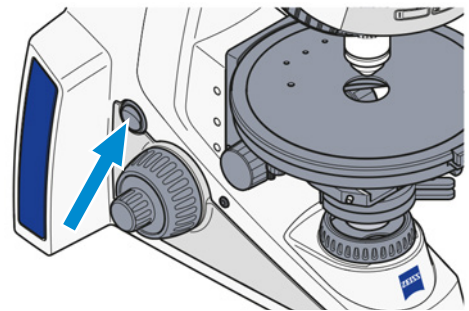

2. Cover the microscope with the dust cover.

6 Care and Maintenance

To ensure the best possible performance of the microscope, maintenance must be performed on a regular basis. Please keep the service logs for your microscope.

To maintain operational safety and reliability of the microscope, we recommend entering into a **ZEISS Protect Service Agreement**.

Info

For additional information and detailed descriptions, refer to further applicable documents or ask your ZEISS Sales & Service Partner.

6.1 Safety During Cleaning and Maintenance

Only conduct preventive measures described here. All tasks of maintenance and cleaning not described may only be performed by an authorized ZEISS service representative.

Any unauthorized intervention or any operation outside the scope of the intended use can lead to injuries and property damage and voids all rights to warranty claims. Only original spare parts from ZEISS may be used.

DANGER

Electric shock due to live parts

When the microscope is still switched on, coming in contact with live parts can lead to electric shock or burn.

- ▶ Switch off the microscope prior to opening or cleaning.
- ▶ Disconnect live parts from the power supply.

NOTICE

Functional impairment due to dirt and moisture

Dirt, dust and moisture can impair the microscope functionality and can cause short-circuits.

- ▶ Use the dust protection cover if the microscope is not used.
- ▶ The ventilation slots must be unobstructed at all times.
- ▶ Perform regular maintenance and cleaning according to the instructions in this document and according to the instructions in the applicable documents.
- ▶ Make sure that no cleaning liquid or moisture gets inside the microscope.
- ▶ In case of damage, the affected parts of the microscope must be taken out of operation.

6.2 Maintenance Schedule

To maintain best possible performance of the microscope, it is essential to perform preventive maintenance on a regular basis. The recommended intervals depend on the total uptime of the microscope.

Interval	Part/Component	Activity
daily	microscope	<p>Check the power cable and the plug for possible damage.</p> <p>If any damage is observed, turn the instrument off and secure it against inadvertent restarts immediately. Call in a qualified professional to remedy the problem.</p>

6.3 Maintenance Work

6.3.1 Cleaning an Optical Surface

NOTICE

Damage of optical surfaces due to improper cleaning

- ▶ Remove dust from the optical surface slowly and carefully.
- ▶ Remove dust on optical surfaces with a natural-hair brush or blow it off with a rubber bellows.
- ▶ Avoid touching optical surfaces with fingers.

- Parts and Tools**
- 🔧 Clean cloth
 - 🔧 Cotton swab
 - 🔧 Optical cleaning solution (85% n-hexan and 15 vol% isopropyl alcohol (IPA))
 - 🔧 Lint-free cloth

- Procedure**
1. Moisten a cotton swab or a clean cloth with an optical cleaning solution, if necessary.
 2. Wipe optical surfaces in a circular motion towards the edge of the optics with slight pressure.

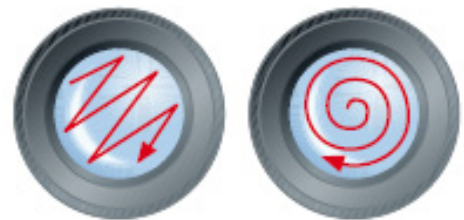

WRONG

CORRECT

3. Dry with a lint-free cloth.

6.3.2 Removing Water-Soluble Contamination

Parts and Tools  Clean cloth
 Lint-free cloth

Prerequisite  The microscope and its components are switched off and disconnected from the power supply.

Procedure

1. Moisten a clean cloth with water.
→ A mild detergent may be added to the water (no solvent!).
2. Wipe off the area with the cloth.
3. Dry with a lint-free cloth.

6.3.3 Exchanging the Fuses T 15 A/H 250 V

 **DANGER**

Electric shock due to live parts

When the microscope is still switched on, coming in contact with live parts can lead to electric shock or burn.

- ▶ Switch off the microscope prior to opening or cleaning.
- ▶ Disconnect live parts from the power supply.

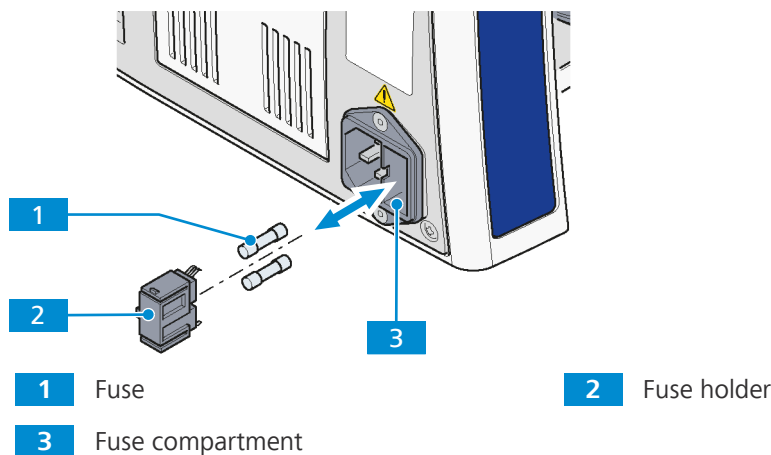

Parts and Tools  2x Fuse type T 15 A/H 250 V

Prerequisite  The microscope is switched off and disconnected from the mains.

Procedure

1. If the fuses fail, first check the cause and remedy technical problems properly.
2. Remove the fuse holder **2** on the rear side of the stand.
3. Remove fuses **1** from the fuse holder.
4. Insert new fuses.
5. Push the fuse holder back into the fuse compartment **3** until it locks in place.
6. Bring the microscope back into operation.

6.3.4 Mechanical Stages

Axiolab 5 stands are fitted with the respective mechanical stage at the factory according to customer requirements.

The friction adjustment of the coaxial knurled knobs is set at an average value at the factory. Should the stage need to be replaced or the stage settings changed, proceed as follows.

6.3.4.1 Adjusting the Drive Length on the Stage Drive

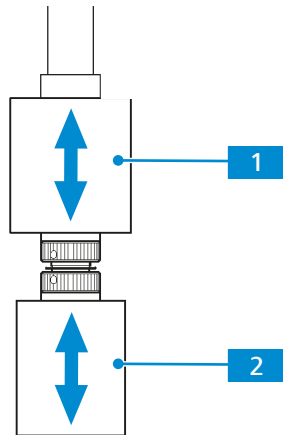

1 Coaxial knurled knob for the Y adjustment

2 Coaxial knurled knob for the X adjustment

- Procedure**
1. Shift or lower the Coaxial knurled knob **1** for the Y adjustment within a range of approx. 15 mm..
 2. Shift or lower the Coaxial knurled knob **2** for the X adjustment within a range of approx. 15 mm.

6.3.4.2 Adjusting the Friction of the Coaxial Knurled Knobs on the Stage Drive

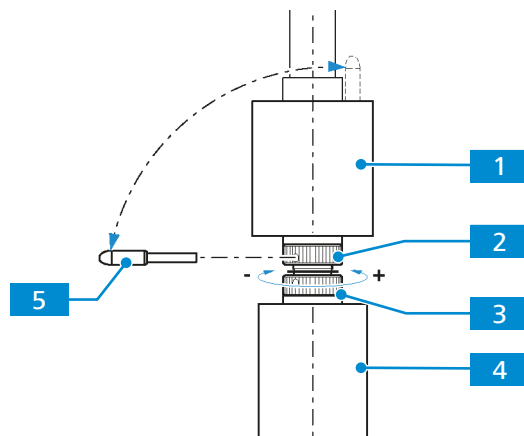

1 Coaxial knurled knob for the Y adjustment

2 Upper hole nut

3 Lower hole nut

4 Coaxial knurled knob for the X adjustment

5 Adjusting pin

X drive

- Procedure**
1. Push the coaxial knurled knob for the X adjustment **4** all the way to the bottom.
 2. Remove the supplied adjusting pin **5** from the coaxial knurled knob for the Y adjustment **1**.
 3. Insert it into one of the holes of the lower hole nut **3**.
 4. Hold the coaxial knurled knob for the X adjustment **4** and turn the hole nut with the adjusting pin clockwise or counter-clockwise until the desired freedom of movement has been achieved.
 - Small friction adjustment: – (clockwise)
 - Large friction adjustment: + (counter-clockwise)
 - It should not be shifted more than one revolution.

Y drive

- Procedure**
1. Push the coaxial knurled knob for the Y adjustment **1** all the way to the top.
 2. Insert the supplied adjusting pin **5** into the hole of the upper hole nut **2**.
 3. Hold the coaxial knurled knob for the Y adjustment **1** and turn the hole nut with the adjusting pin clockwise or counter-clockwise until the desired freedom of movement has been achieved.
 - Small friction adjustment: – (clockwise)
 - Large friction adjustment: + (counter-clockwise)
 - It should not be shifted more than one revolution.
 4. Re-insert the adjusting pin into the coaxial knurled knob for the Y adjustment.

7 Troubleshooting

The following table provides hints for solving common problems. If you cannot solve the problem or if you are unsure about a certain technical difficulty, contact your local ZEISS service representative.

Symptom	Cause	Measure
No illumination light after switching on the microscope	Nosepiece and/or reflector turret are not engaged to defined positions.	Move the nosepiece and/or reflector turret to the left or right to engage the nosepiece and/or reflector turret to defined positions.
Shadows or inhomogeneous image brightness in the field of view; the field is not entirely visible	The vis/phot push-pull rod/shift knob on the photo tube is not in the correct functional position (intermediate position).	Move the vis/phot push-pull rod/shift knob to the correct functional position (end position).
	The nosepiece with objective is not engaged in the click-stop.	Push in nosepiece with objective until it engages.
	The condenser is not correctly adjusted.	<i>Set the condenser [▶ 63] correctly (adjustment, centering).</i>
	The aperture diaphragm is not correctly adjusted.	<i>Set the aperture diaphragm [▶ 63] correctly (opening).</i>
	The luminous-field aperture is not correctly adjusted.	<i>Set the luminous-field diaphragm [▶ 63] correctly (opening).</i>
	The filter has not been inserted correctly in the filter mount.	Insert filter correctly in the filter mount.
Asymmetric image sharpness, e.g. one side is sharp, one side is blurred	The condenser is not correctly adjusted.	<i>Set the condenser [▶ 63] correctly.</i>
	The nosepiece is not engaged in its locking position.	Engage the nosepiece in its locking position (click-stop).
	The sample has not been fixed on the mechanical stage.	Insert and fix the sample correctly in the sample holder.
Distinct focus differences when changing the objective	Focusable eyepieces are not adjusted correctly.	<i>Adjust the focusable eyepieces [▶ 59] according to the vision defect.</i>
	A Pol eyepiece was used in a binocular tube without upright image.	Use a matching eyepiece.
	The objective is not screwed in all the way.	Screw the objective in to the stop.
	The tube lens is not mounted, or mounted unnecessarily.	Mount the tube lens or remove it, as appropriate. If necessary, call in service personnel for check/repair.

Symptom	Cause	Measure
Low resolving power and poor image contrast	The aperture diaphragm is not correctly adjusted.	<i>Set the aperture diaphragm [▶ 63] as per 2/3 rule or the sample features.</i>
	The condenser is not correctly focused and the front lens 0.9 is not swivelled in and out correctly.	<i>Focus the condenser [▶ 63] and swivel front lens 0.9 in or out correctly.</i>
	A wrong cover glass thickness for transmitted light objectives corrected for 0.17 mm cover glass thickness is used.	Use standard cover glass with a thickness of 0.17 mm.
	The sample slide is placed upside down.	Turn the sample slide over; the sample side should be on top.
	Immersion objectives are used with no or non-specified immersion oil.	Use immersion oil 518 N or 518 F from ZEISS.
	The immersion oil contains air bubbles.	Repeat the oiling procedure with fresh oil.
	The front lens of a dry objective is soiled with immersion oil.	Clean the front lens of the dry objective.
	Correction setting is not set to the proper thickness of the cover glass.	Adjust the correction setting ring to the correct cover glass thickness.
Left and the right field of view cannot be brought together in one image	Dirt or dust on the optical surfaces of objectives, eyepieces, condensers or filters.	Clean the respective optical components.
	The eyepiece distance (interpupillary distance) is not adjusted correctly.	<i>Adjust the inter-pupillary distance [▶ 59] correctly.</i>
Eye fatigue when using the microscope	The focusable eyepieces are not adjusted correctly.	<i>Adjust the focusable eyepieces [▶ 59] according to the vision defect.</i>
	The eyepiece distance (interpupillary distance) is not adjusted correctly.	<i>Adjust the inter-pupillary distance [▶ 59] correctly.</i>
	The focusable eyepieces are not adjusted correctly.	<i>Adjust the focusable eyepieces [▶ 59] according to the vision defect.</i>
	The image brightness is unacceptable.	Adjust the lamp brightness or insert a conversion filter.
	The binocular tube is optically/mechanically misaligned.	Call in service personnel for check/repair.

Symptom	Cause	Measure
Dirt or dust in the field of view	The condenser is not correctly focused and the front lens 0.9 is not swivelled in and out correctly.	<i>Focus the condenser [▶ 63] and swivel front lens correctly in or out.</i>
	The opening of the aperture diaphragm is too small.	<i>Set the aperture diaphragm [▶ 63] as per 2/3 rule or the sample features.</i>
	Dirt or dust on optical surfaces of objectives, eyepieces, condensers, filters or samples.	<i>Clean the optical surfaces [▶ 89] of the soiled components.</i>
LED/halogen lamp does not light up although the switch is in the On position	The power plug is not plugged into the mains outlet.	Insert the plug into the mains outlet. Ensure that the outlet and instrument have the same voltage.
	The lamp is not installed.	<i>Install lamp for transmitted light [▶ 126] or reflected light [▶ 130].</i>
	The lamp is defective.	<i>Replace lamp for transmitted light [▶ 126] or reflected light [▶ 130].</i>
	The fuses are defective.	<i>Replace fuses [▶ 90].</i>
	The installed electrical equipment may be defective.	Call in the service personnel to check components and replace if necessary.
	The power socket does not supply voltage.	Use a different mains power socket.
Halogen lamp flickers, illumination intensity is not stable	The halogen lamp is reaching the end of its service life.	<i>Replace lamp for transmitted light [▶ 126] or reflected light [▶ 130].</i>
	The power cable is not installed properly or is damaged.	Install the power cable properly or replace it.
	The plug of the LED/halogen lamp is not properly inserted in the socket.	<i>Insert the lamp plug for transmitted light [▶ 126] or reflected light [▶ 130] correctly.</i>
No light in eyepiece	The system is in ECO mode.	Turn the Intensity/LM knob clockwise to wake up the system.
	The light intensity is too low.	Turn the Intensity/LM knob clockwise to increase the light.
	The light was turned off by pressing the corresponding RL/TL button.	Press the RL or TL button according to the corresponding indicator (green).
	A wrong or missing reflector module for reflected light is in use.	Check the reflector turret and make sure the correct reflector is in use.

7.1 Resetting the Microscope to Factory Settings

NOTICE

Please use this function with caution as it will reset all existing configurations.

The default factory settings are:

- The Light Manager is enabled, but no light intensity values are saved.
- The light intensity is set to the initial minimum value.
- All stored configurations are cleared.

Prerequisite ✓ The microscope is operational.

Procedure 1. Press and hold down the **Intensity/LM knob** for 20 seconds.

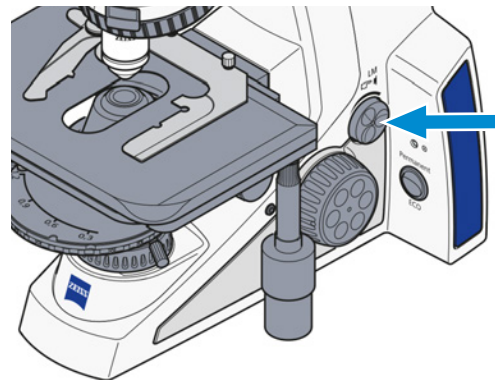

- While the **Intensity/LM knob** is held down from 3 s to 20 s, the indicator light blinks RED.
 - It blinks GREEN after 20 s are reached.
- ↳ When the indicator light stops blinking and remains GREEN, the reset to the default factory setting is successful.

8 Decommissioning and Disposal

This chapter contains information on the decommissioning and disposal of the microscope and its expansions/components or accessories.

8.1 Decommissioning

If the microscope and its components are not used for an extended period of time such as several months, they should be shut down completely and secured against unauthorized access.

DANGER

Electric shock due to live parts

When the microscope is still switched on, coming in contact with live parts can lead to electric shock or burn.

- ▶ Switch off the microscope prior to opening or cleaning.
- ▶ Disconnect live parts from the power supply.

- Procedure**
1. Switch off the microscope.
 2. Pull the power supply plug.
 3. Protect microscope using a dust cover.

8.2 Transport and Storage

The following regulations must be observed before and during transport:

- The boxes must be secured during transport.
 - Avoid rocking the boxes back and forth.
 - Note the weight information on the package and on the shipping document.
 - Where possible, the original packaging must be used for shipping or transport.
- Maximum shock resistance**
- Do not drop or bump the boxes during movement or storage. Any acceleration shall be < 10 g.
 - Evaluate packaging shock and tilting sensors on delivery and after internal transport.
- Allowable temperature**
- Allowable temperature during transport in packaging:
- Between -40 °C and +70 °C
 - Relative humidity (without condensation) less than 75 % at 35 °C
- Allowable temperature during storage:
- Between +10 °C and +40 °C
 - Relative humidity (without condensation) less than 75 % at 35 °C

Info

24 hours before installation of the microscope it is required that the boxes be at recommended room temperature to avoid ingress of humidity, which is very harmful to optical paths, and to ensure effective stability of the microscope during installation and testing.

8.3 Disposal

The microscope and its components must not be disposed of as domestic waste or through municipal disposal companies. They must be disposed of in accordance with applicable regulations (WEEE Directive 2012/19/EU). ZEISS has implemented a system for the return and recycling of devices in member states of the European Union that ensures suitable reuse according to the EU Directives mentioned. The customer is responsible for decontamination.

Info

Detailed information on disposal and recycling is available from your ZEISS Sales & Service Partner.

8.4 Decontamination

A decontamination statement must be submitted before returning any used objects to the ZEISS location.

If reliable decontamination cannot be guaranteed, the hazard must be marked according to applicable regulations. In general, a well-visible warning sign must be affixed to the article itself and to the outside of the packaging, together with detailed information on the type of contamination.

9 Technical Data and Conformity

This chapter contains important technical data as well as information on the conformity.

9.1 Performance Data and Specifications

Due to continuous development, we reserve the right to change specifications without notice.

Info

Your ZEISS Sales & Service Partner will provide you with the detailed installation requirements.

Weight and Sizes

Main Components	Width (mm)	Depth (mm)	Height (mm)	Weight (kg)
Basic stand without tube	approx. 210	approx. 304	approx. 357.5	approx. 8 to 20

Location requirements

The microscope may only be operated in closed rooms. The microscope should not be installed near radiators or windows with direct sunlight. The microscope must be placed securely on the table surface to prevent slipping and falling.

Compliance with the installation requirements of the microscope and the availability of the requested supplies is the responsibility of the customer and has to be readily available at the time of installation.

Installation site	Exclusively inside buildings
-------------------	------------------------------

Altitude	Max. 2000 m above sea level
----------	-----------------------------

Atmospheric pressure	Min. 800 hPa
----------------------	--------------

Air Conditioning and Quality

Temperature for operation	+10 °C to + 40 °C
---------------------------	-------------------

Relative humidity (without condensation)	< 75 %
--	--------

Atmospheric pressure / altitude	800 to 1060 hPa / ≤ 2000 m above sea level
---------------------------------	--

Pollution degree	2
------------------	---

Operational area	closed rooms
------------------	--------------

Mains connection

Protection class	I
------------------	---

Ingress protection rating	IP20 (IEC 60529)
---------------------------	------------------

Oversvoltage Category	II
-----------------------	----

Nominal AC voltage	100 to 240 V (AC), ±10 %
--------------------	--------------------------

Nominal frequency	50 to 60 Hz
-------------------	-------------

Power consumption	max. 100 VA
-------------------	-------------

Main power plug	Local mains plug will be supplied.
-----------------	------------------------------------

Addition building PE	The system must be connected to a building earth point at all times.
----------------------	--

Fuses in the stand	2x T 3.15 A/H, 5x20 mm (in compliance with IEC 127)
--------------------	---

LED illumination TL/RL	Power consumption	max. 10 VA		
	Adjustment of light source	continuous approx. 10 to 800 mA		
Halogen illumination TL/RL	Power consumption	max. 35 VA		
	Adjustment of light source	continuous approx. 0.5 to 12 V		
LED illumination fluorescence TL	Wavelengths optional	385, 470, 505, 565, 625 nm		
Stand specifications	Focusing	manual stage focusing		
	Coarse focusing	approx. 4 mm/revolution		
	Fine focusing	approx. 0.4 mm/revolution; 4 µm scale interval		
	Lifting range	depending on the stand, 15 mm/30 mm		
	Height stop	factory pre-set		
	Objective change	manual		
	Reflector module change	manual		
Tube specifications	Type	Viewing angle	Adjustment	Viewing height* in mm
	Binocular tube 30°/23	30°	- None -	449/485
	Binocular photo tube 30°/23 (50:50)	30°	- None -	449/485
	Binocular photo tube 30°/23 (100:100)	30°	- None -	449/485
	Binocular photo tube 20°/23 (100:100)	20°	- None -	442/481
	Binocular ergo tube 15°/23 (50/50), telescopic, height, up-right image	15°	height, telescopic	410/509
	Binocular tube 20°/23	20°	- None -	442/481
	Binocular photo tube 20°/23 Pol (100:100)	20°	- None -	442/481
	Binocular ergo tube 20°/23 (100/100), reverse image, 44 mm height	20°	height	457/574
	* Range between the lower and upper setting of the eyepieces, e.g. 442/481 → 442 mm to 481 mm			
All specifications are for an inter-pupillary distance of 65 mm.				

9.2 Applicable Standards and Regulations

Observe all general and country-specific safety regulations as well as applicable environmental protection laws and regulations.

The microscope is in compliance with the requirements of the following regulations and directives:

2011/65/EU	Directive 2011/65/EU of the European Parliament and of the Council of 8 June 2011 on the restriction of the use of certain hazardous substances in electrical and electronic equipment (RoHS)
2015/863/EU	Commission Delegated Directive (EU) 2015/863 of 31 March 2015 amending Annex II to Directive 2011/65/EU of the European Parliament and of the Council as regards the list of restricted substances (RoHS Directive III)
EN 61010-1:2019	Safety requirements for electrical equipment for measurement, control, and laboratory use – Part 1: General requirements
EN IEC 61326-1:2021	Electrical equipment for measurement, control and laboratory use - EMC requirements - Part 1: General requirements

According to directive 2011/65/EU (RoHS) the microscope and its accessories have been classified as instrument category 9 (Monitoring and control instruments including industrial monitoring and control instruments). They also fall under 2012/19/EU (WEEE).

European and International Directives / Standards: For more information on ISO and CSA certificates or CE Declarations of Conformity, contact your ZEISS Sales & Service Partner.

ZEISS works according to a certified Environment Management System according to ISO 14001. The microscope and its components were developed, tested, and produced in accordance with the valid regulations and guidelines for environmental law of the European Union.

Only applicable for Axiolab 5 materials

2014/30/EU	Directive 2014/30/EU of the European Parliament and of the Council of 26 February 2014 on the harmonization of the laws of the Member States relating to electromagnetic compatibility
2014/35/EU	Directive 2014/35/EU of the European Parliament and of the Council of 26 February 2014 on the harmonization of the laws of the Member States relating to the making available on the market of electrical equipment designed for use within certain voltage limits

Only applicable for Axiolab 5

2017/746/EU

Regulation (EU) 2017/746 of the European Parliament and of the Council of 5 April 2017 on in vitro diagnostic medical devices and repealing Directive 98/79/EC and Commission Decision 2010/227/EU

EN 61010-2-101:2017

Safety requirements for electrical equipment for measurement, control and laboratory use - Part 2-101: Particular requirements for in vitro diagnostic (IVD) medical equipment

EN IEC 61326-2-6:2021

Electrical equipment for measurement, control and laboratory use - EMC requirements - Part 2-6: Particular requirements - In vitro diagnostic (IVD) medical equipment

10 Accessories and System Expansions

Only the following accessories may be used with the microscope as their safe use has been confirmed by ZEISS. Only original parts from ZEISS may be used. Check in advance whether your microscope can be retrofitted with a system expansion or accessories.

After installation or conversion it must be carefully checked whether the microscope and its system expansions/accessories are in a safe operational state and whether unused ports are closed. For details and safety measures please refer to the associated documents.

Info

For additional information and detailed descriptions, refer to further applicable documents or ask your ZEISS Sales & Service Partner.

Name	Description/Info
Objectives	<p>The performance of the microscope objectives affects the image quality of your microscope like no other system component. Whether you work with histological samples, cell samples or entire organisms – the suitability of microscope objectives for your application depends on various factors.</p> <p>More detailed information on available and recommended objectives can be found at https://www.micro-shop.zeiss.com/de/de/shop/objectives or ask your ZEISS Sales & Service Partner.</p>
Sliders	<p>The following sliders are available:</p> <ul style="list-style-type: none"> ▪ Analyzer slider D/A, with lambda plate, 360° rotatable ▪ Analyzer slider D/A, 360° rotatable ▪ Analyzer slider D/A, 360° fixed ▪ Analyzer slider D/A, with lambda plate, each rotatable +/- 10° ▪ Slider 12x46, with focusing Bertrand lens, for phase contrast and conoscopy
Polarizers	<p>The following polarizers are available:</p> <ul style="list-style-type: none"> ▪ Polarizer D, fixed, removable ▪ Polarizer D, 90°, rotatable, removable ▪ Polarizer, fixed, with lambda plate, rotatable ▪ Polarizer, rotatable, with color filter carrier ▪ Circular polarizer D ▪ Low-power system for objectives 2.5x/4x for condenser 0.9/1.25 H ▪ Color filter carrier 3x for filter d=32 mm
Color filters	<p>The following color filters are available:</p> <ul style="list-style-type: none"> ▪ Interference wide-band filter, green, d=32x4 ▪ Heat absorbing filter KG 1, d=32x2 ▪ Neutral density filter 0.06, d=32x2 ▪ Neutral density filter 0.25, d=32x2 ▪ Polarizing filter 32 mm

Name	Description/Info
Eyepieces	<p>The following eyepieces and accessories are available:</p> <ul style="list-style-type: none"> ▪ Eyepiece E-PL 10x/23 GW, foc. ▪ Eyepiece PL 16x/16 GW, foc. ▪ Eyepiece PL 10x/23 GW, foc. POL with crossline graticule ▪ Eyepiece PL 10x/23 GW, foc. ▪ Auxiliary microscope ▪ Pinhole diaphragm D= 30 mm
Condensers	<p>The following condensers are available:</p> <ul style="list-style-type: none"> ▪ Ultra condenser 1.2/1.4 (0.75-1.0) ▪ Dry darkfield condenser 0.8/0.95 (0.6-0.75) ▪ Condenser 0.9/1.25 H ▪ Condenser 0.9 H Pol ▪ Condenser, achrom.-aplan. 0.9 BF ▪ Condenser, achrom.-aplan. 0.9 BF DF PhC DIC ▪ Condenser, achrom.-aplan. 0.9 BF Pol
Stages	<p>The following stages are available:</p> <ul style="list-style-type: none"> ▪ Rackless mechanical stage, 75x30 R ▪ Rackless mechanical stage, 75x50 R ▪ Rackless mechanical stage, 75x50 L ▪ Mechanical stage 75x30 R ▪ Pol rotary stage, 360°, with clamping device
Sample holders	<p>The following sample holders are available:</p> <ul style="list-style-type: none"> ▪ Specimen holder for single slide, one-hand operation with spring lever, left ▪ Specimen holder for double slides 76x26 ▪ Attachable Pol object guide, 47x27 mm
Light sources	<p>The following light sources are available:</p> <ul style="list-style-type: none"> ▪ LED module 625 nm for FL ▪ LED module 505 nm for FL ▪ LED module 470 nm for FL ▪ LED module 385 nm for FL ▪ LED module 565 nm for FL ▪ Illuminator TL/RL LED 10 Axiolab
Tubes	<p>The following tubes are available:</p> <ul style="list-style-type: none"> ▪ Binocular ergophototube 20°/23 (100:0/0:100), reversed image ▪ Binocular phototube, Pol, 20°/23 (100:0/0:100), upright image ▪ Binocular tube 30°/23, reversed image ▪ Binocular tube 30°/23, upright image ▪ Binocular phototube, 30°/23 (50:50), reversed image ▪ Binocular phototube, 30°/23 (100:0/0:100), reversed image ▪ Binocular phototube, 20°/23 (100:0/0:100), upright image

Name	Description/Info
Cameras	<p>The following cameras and accessories are available:</p> <ul style="list-style-type: none"> ▪ Axiocam 202 mono (see separate instruction manual) ▪ Axiocam 208 color (see separate instruction manual) ▪ Camera adapter 60N-C 2/3" 0.5x ▪ Camera adapter 60N-C 2/3" 0.63x ▪ Camera adapter 60N-C 1" 1.0x ▪ Video adapter 60 C 1/3" 0.4x

10.1 Assembling the Reversible Eyecups

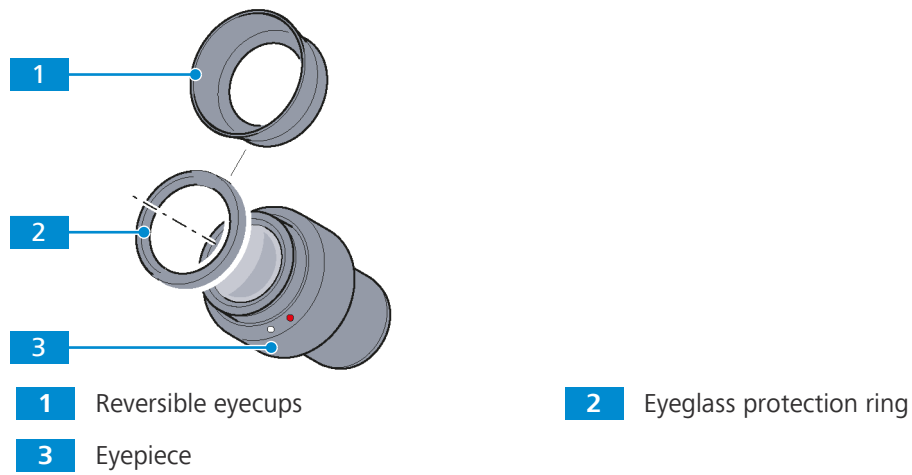

- Procedure**
1. Remove the eyeglass protection ring **2** from the eyepiece **3**.
 2. Mount the reversible eyecup **1**.

Sometimes the eyeglass protection rings are seated very tightly in the eyepiece groove, so you may need a blunt sample (wooden stick) to prod them off.

10.2 Binocular Tubes

10.2.1 Binocular Tube 30°/23

Purpose Binocular tubes are used to visualize the microscopic image by means of the eyepieces.

Position The binocular tubes are mounted on the top of the stand.

Function The pupil distance and the viewing height can be adjusted with the aid of the binocular section.

The following features and controls are available:

- Optionally with upright or reversed image
- viewing angle 30°
- field of view 23 mm

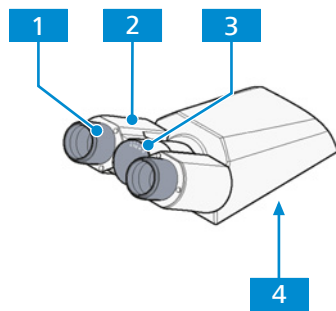

Fig. 30: Binocular Tube 30°/23

- | | |
|--------------------------|------------------------------|
| 1 Eyepiece socket | 2 Binocular section |
| 3 Angle scale | 4 Dovetail ring mount |

10.2.2 Binocular Photo Tube Pol 20°/23 (100:0/0:100)

Purpose Binocular photo tubes are used to visualize the microscopic image by means of the eyepieces. Using the camera port, the microscopic image can be sent to a connected camera.

Position The binocular photo tubes are mounted on the top of the stand.

Function The pupil distance and the viewing height can be adjusted with the aid of the binocular section.

The following features and controls are available:

- upright image
- camera port with toggle graduation (100:0/0:100)
- viewing angle 20°
- field of view 23 mm

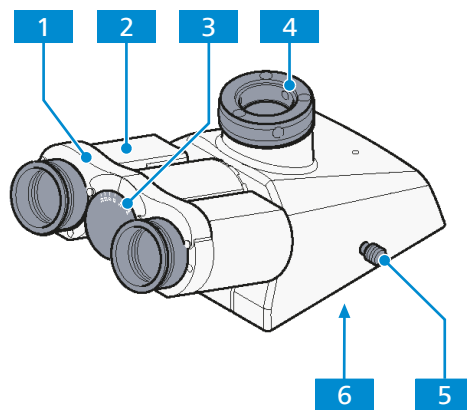

Fig. 31: Binocular Photo Tube Pol 20°/23 (100:0/0:100)

- | | |
|--|------------------------------|
| 1 Eyepiece socket | 2 Binocular section |
| 3 Angle scale | 4 Camera port |
| 5 Slider for selecting the graduation | 6 Dovetail ring mount |
- Slider pushed in: 100% light to eyepieces
 - Slider pulled out: 100% light to camera. 100% light to camera

10.2.3 Binocular Ergo Photo Tube 20°/23 (100:0/0:100)

Purpose Binocular photo tubes are used to visualize the microscopic image by means of the eyepieces. Using the camera port, the microscopic image can be sent to a connected camera.

Position The binocular photo tubes are mounted on the top of the stand.

Function The pupil distance and the viewing height can be adjusted with the aid of the binocular section. The following features and controls are available:

- upright image
- camera port with toggle graduation (100:0/0:100)
- viewing angle 20°
- field of view 23 mm, usable 22 mm
- vertical adjustment of 44 mm with vertical scale

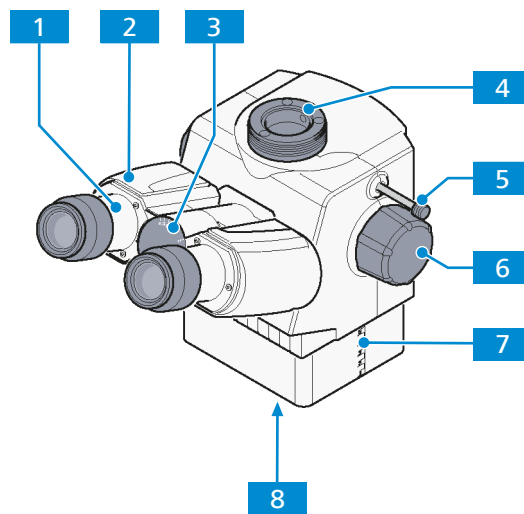
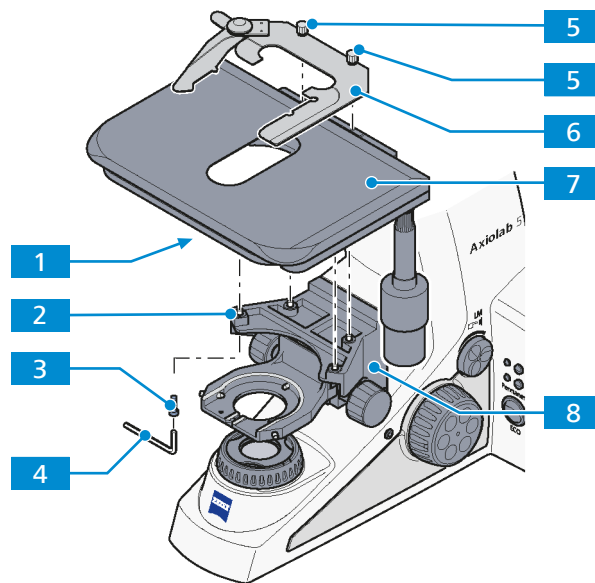

Fig. 32: Binocular Ergo Photo Tube 20°/23 (100:0/0:100)

- | | |
|---|---|
| 1 Eyepiece socket | 2 Binocular section |
| 3 Angle scale | 4 Camera port |
| 5 Slider for selecting the graduation <ul style="list-style-type: none"> ▪ Slider pushed in: 100% light to eyepieces ▪ Slider pulled out: 100% light to camera | 6 Rotary knob for vertical adjustment (right and left) |
| 7 Vertical scale | 8 Dovetail ring mount |

10.3 Stages

10.3.1 Assembling a Mechanical Stage and Sample Holder



- | | | | |
|----------|---|----------|----------------------------|
| 1 | Threaded holes on the bottom of the stage | 2 | Stage carrier opening (4x) |
| 3 | Fastening screw (4x) | 4 | Hex key (3 mm) |
| 5 | Clamping screw | 6 | Sample holder |
| 7 | Mechanical stage | 8 | Stage carrier |

Parts and Tools  Hex Key, 3.0 mm

- Procedure**
1. Place the stage **7** on the stage carrier **8** so that the threaded holes **1** on the bottom of the stage are positioned above the stage carrier openings **2** and hold the stage.
 2. Insert four fastening screws **3** through the stage carrier from below and screw them into the bottom of the stage.
 3. Turn the stage to orient it in an XY direction and tighten the fastening screws.
 4. Place the sample holder **6** on the stage and fasten the two clamping screws **5**.

10.3.2 Removing a Mechanical Stage and Sample Holder

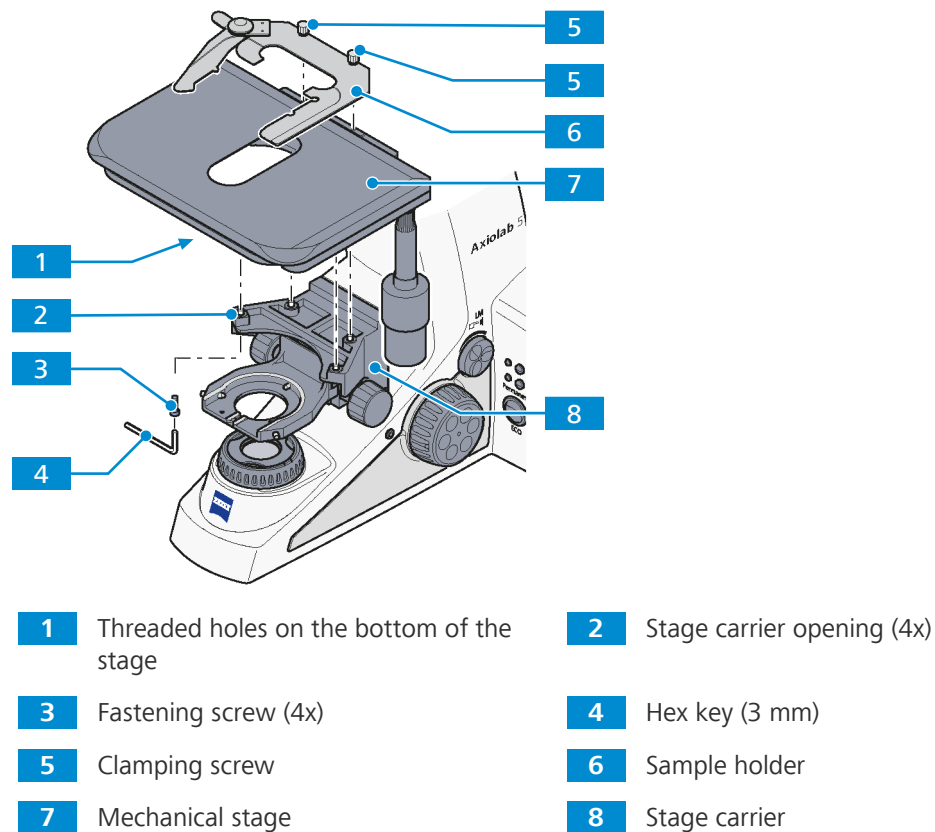

Parts and Tools  Hex Key, 3.0 mm

Procedure

1. Loosen the two clamping screws **5** of the sample holder **6**.
2. Remove the sample holder.
3. Hold the stage **7** and remove the four fastening screws **3** on the stage carrier.
4. Remove stage upwards from the stage carrier **8**.

10.3.3 Rackless Mechanical Stage, 75x30 R

Purpose Mechanical stages are used for fixing and positioning the sample for examination.

Position The mechanical stages are mounted on the stage carrier of the stand.

Function The sample is fixed on the stage by means of the sample holder. For this purpose, the sample holder is equipped with a spring lever.

The sample is positioned in the beam path by means of the two coaxial drives in X and Y direction. The adjustment range can be read off the respective vernier scale.

The following features and controls are available:

- rackless stage
- coaxial drives in X and Y adjustment on the right (R)
- travel range 75x30mm
- with hardcoat anodized surface

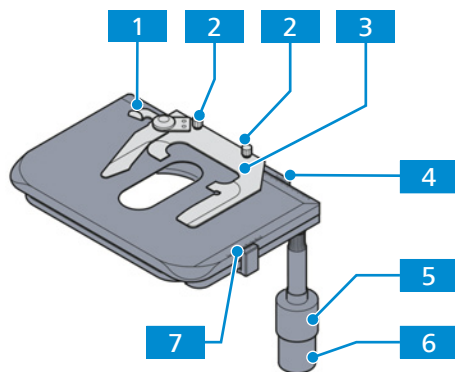

Fig. 33: Rackless mechanical stage, 75x30 R

1 Spring lever

3 Sample holder for one slide

5 Coaxial knurled knob for Y adjustment

7 Vernier scale for display of the adjustment range in Y

2 Knurled screw (2x) for fixing the sample holder to the stage

4 Vernier scale for display of the adjustment range in X

6 Coaxial knurled knob for X adjustment

10.3.4 Mechanical Stage, 75x30 R

Purpose Mechanical stages are used for fixing and positioning the sample for examination.

Position The mechanical stages are mounted on the stage carrier of the stand.

Function The sample is fixed on the stage by means of the sample holder. For this purpose, the sample holder is equipped with a spring lever.

The sample is positioned in the beam path by means of the two coaxial drives in X and Y direction. The adjustment range can be read off the respective vernier scale.

The following features and controls are available:

- stage with rack and pinion
- coaxial drives in X and Y adjustment on the right (R)
- travel range 75x30mm
- with hardcoat anodized surface

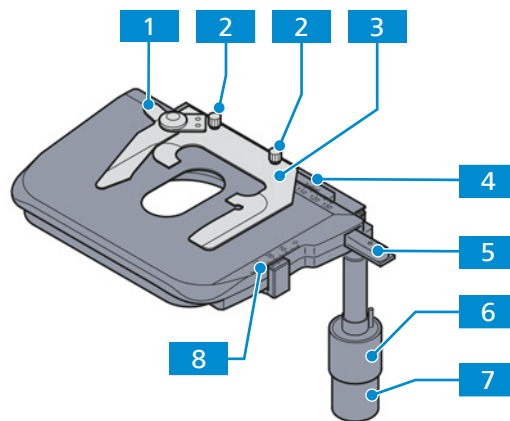

Fig. 34: Mechanical Stage, 75x30 R

- | | |
|---|--|
| <p>1 Spring lever</p> <p>3 Specimen holder for one slide</p> <p>5 Rack</p> <p>7 Coaxial knurled knob for X adjustment</p> | <p>2 Knurled screw (2x) for fixing the sample holder to the stage</p> <p>4 Vernier scale for display of the adjustment range in X</p> <p>6 Coaxial knurled knob for Y adjustment</p> <p>8 Vernier scale for display of the adjustment range in Y</p> |
|---|--|

10.3.5 Rotary Stage Pol 360° with Sample Guide

Purpose Rotary stages are used for fixing and positioning the sample for examination in polarized light.

Position The rotary stages are mounted on the stage carrier of the stand.

Function The sample is fixed on the stage by means of the sample guide. For this purpose, the sample guide is equipped with a spring lever.

The sample is positioned in the beam path by means of the two knurled knobs of the sample guide. The adjustment range can be read off the respective vernier scale.

The following features and controls are available:

- optionally equipped with: attachable sample guide for use of standard slides 45x25 mm and 75x25 mm (3"x1")
- 360° rotation with lock
- click stop every 45°; enabled or disabled via the control knob

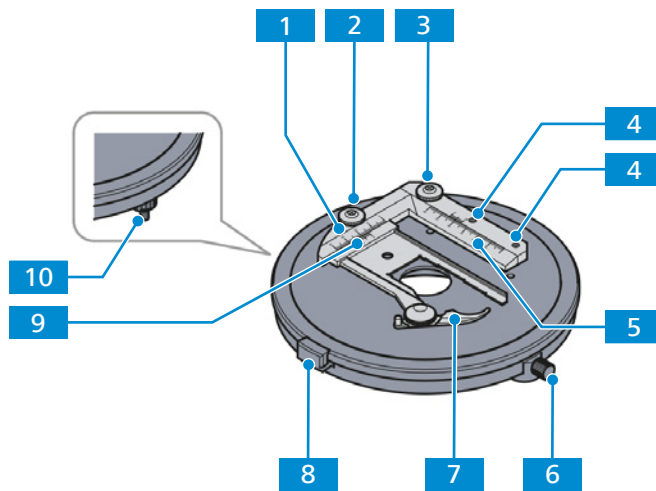
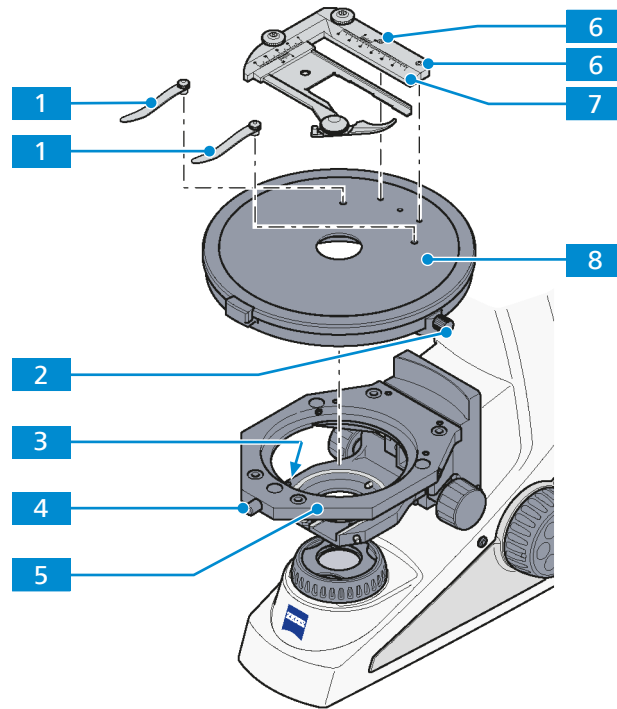

Fig. 35: Rotary Stage Pol 360° with sample Guide

- | | |
|--|--|
| <p>1 sample guide</p> <p>3 Knurled knob for adjustment in X direction</p> <p>5 Vernier scale for display of the adjustment range in X</p> <p>7 Spring lever</p> <p>9 Vernier scale for display of the adjustment range in Y</p> | <p>2 Knurled knob for adjustment in Y direction</p> <p>4 Clamping screw (2x, AF 2) for fixing the sample guide to the stage</p> <p>6 Knurled screw for locking the rotation, 360° rotation possible</p> <p>8 Click stop every 45°</p> <p>10 Control knob to enable/disable the clip stop function</p> |
|--|--|

10.3.5.1 Removing the Rotary Stage and Sample Guide or Clamping Device



- | | | | |
|----------|---------------------------------|----------|--|
| 1 | Clamping device | 2 | Knurled screw for locking the rotation |
| 3 | Spring-loaded pin | 4 | Screw cap |
| 5 | Stage carrier for rotary stages | 6 | Clamping screw (2x) |
| 7 | Sample guide | 8 | Rotary stage |

Parts and Tools  Hex Key, 2.0 mm

Procedure

1. Loosen the screw cap **4** from the spring housing (about three rotations).
2. Press the rotary stage **8** to the front against the spring-loaded pin **3**, lift it off the stage carrier **5** from the back and remove it upwards.
3. Re-tighten the screw cap.
4. If available, loosen the two clamping screws **6** on the sample guide **7**.
5. Remove the sample guide by lifting it upwards.
6. If available, remove the clamping device **1** from the rotary stage.

10.3.5.2 Assembling the Rotary Stage and Sample Guide or Clamping Device

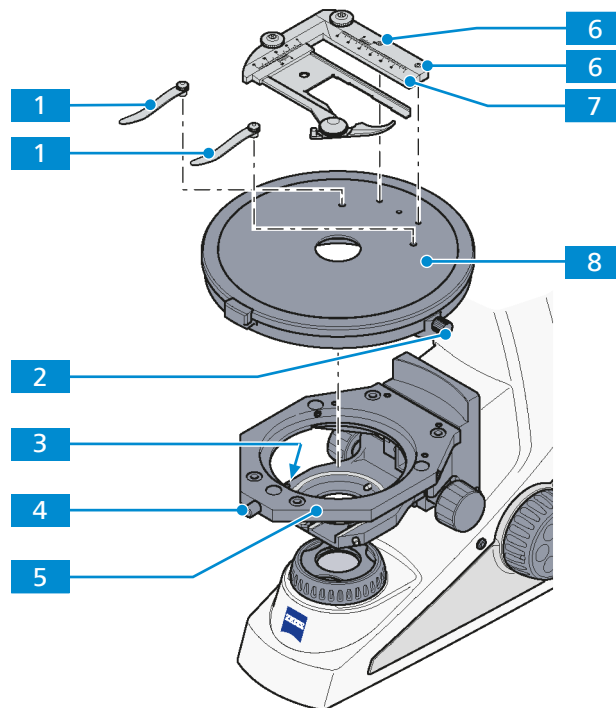

- | | | | |
|----------|---------------------------------|----------|--|
| 1 | Clamping device | 2 | Knurled screw for locking the rotation |
| 3 | Spring-loaded pin | 4 | Screw cap |
| 5 | Stage carrier for rotary stages | 6 | Clamping screw (2x) |
| 7 | Specimen guide | 8 | Rotary stage |

- Procedure**
1. Loosen the screw cap **4** of the spring housing with approx. three rotations.
 2. Place the rotary stage **8** with the groove of the dovetail (stage bottom) on the spring-loaded pin **3**.
 3. Attach the rotary stage with the knurled screw for locking the rotation **2** pointing to the front right.
 4. Press the rotary stage to the front against the spring-loaded pin and lower it towards the back into the stage carrier **5**, then release it.
 5. Re-tighten the screw cap.
 6. If required, insert the clamping device **1** into the holes provided.
 7. If required, insert the sample guide **7** with the two cylindrical pins on the underside into the holes provided and tighten the two clamping screws **6**. Use a 2 mm hex key.

10.3.5.3 Centering the Rotary Stage

With high-power objectives, centering can be exact only for one selected objective.

All stages are factory-precentered, i.e. while rotating the stage the sample detail set to the center will remain in the center. If the sample detail moves out of the center of the field of view while the stage is being rotated, the stage should be re-centered.

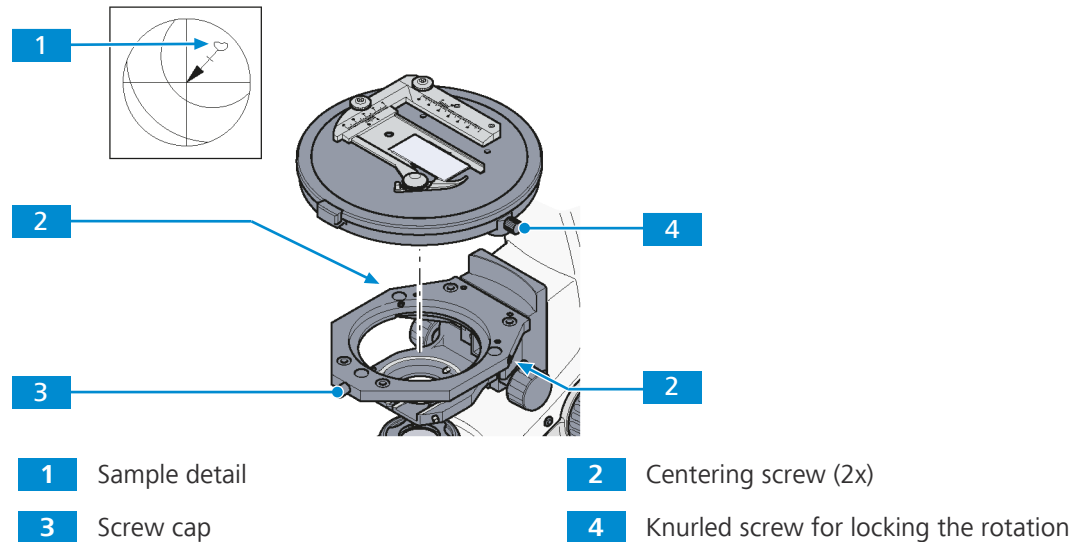

Parts and Tools  Hex key, 1.5 mm

- Prerequisite**
- ✓ The rotary stage is installed in the stage carrier.
 - ✓ A high-contrast sample and an eyepiece with a crossline reticle are available.
 - ✓ The microscope is adjusted for *transmitted light brightfield microscopy* [[▶ 63](#)].

- Procedure**
1. Turn the nosepiece to swing the non-centering objective mount.
 2. Loosen the knurled screw for locking the rotation **4** and the screw cap **3** on the stage carrier.
 3. Rotate the stage to determine the position of maximum offset of the sample feature **1** (origin of arrow) from the center of the eyepiece reticle.
 4. Reset the two centering screws **2** on the stage carrier to move the sample detail by half an arrow length in the direction of the crossline center.
 5. Check whether the sample detail moves when the stage is rotated again; repeat the procedure, if required.
 6. Re-tighten the screw cap.

10.3.5.4 Centering the Objectives of the Polarization Stand

Purpose Stage centering of the non-centering objective mount is necessary to ensure that a sample feature located in the center of the field of view does not drift out while rotating the stage. By centering of the remaining objectives, the sample feature remains in the center of the field of view even after changing the objective.

The nosepiece 5x Pol is equipped with one fixed and four centerable objective positions.

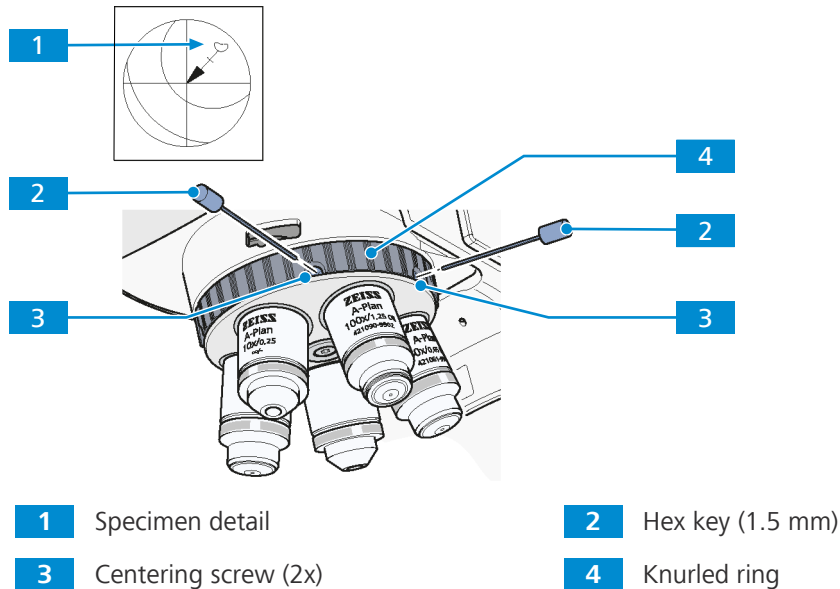

Parts and Tools 2 x Hex key, 1.5 mm

- Prerequisite**
- ✓ The microscope is adjusted for *transmitted light brightfield microscopy* [[▶ 63](#)].
 - ✓ The *rotary stage* [[▶ 115](#)] is centered.
 - ✓ A high-contrast sample and an eyepiece with crossline reticle are available.

- Procedure**
1. Turn the nosepiece using the knurled ring **4** of the nosepiece to swing the non-centering objective position.
 2. Check if the rotary stage is centered to this objective.
 3. Turn the nosepiece to move a centering objective mount into the beam path.
 4. Rotate the stage to determine the position of maximum offset of the sample detail **1** (origin of the arrow) from the center of the eyepiece reticle.
 5. Reset the two centering screws **3** of the nosepiece position to move the sample detail by half the arrow length in the direction of the crossline center.
 6. Check whether the sample detail moves when the stage is rotated again; repeat the procedure if required.
 7. Center the other three objectives in the same manner.

10.4 Analyzer Sliders

10.4.1 Analyzer Slider TL/RL, Fixed

Purpose The analyzer slider is used to set the polarization contrast technique.

Position The analyzer slider is inserted into the 12x46 slot of the intermediate plate for analyzer slider 12x46 mounted between stand and tube.

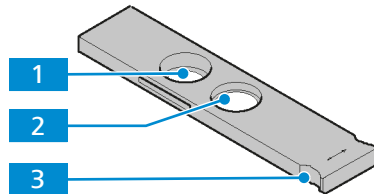

Fig. 36: Analyzer slider TL/RL, fixed

- | | |
|-------------------------|-------------------|
| 1 Empty position | 2 Analyzer |
| 3 Handle | |

10.4.2 Analyzer Slider TL/RL, with Lambda Plate, 360° Rotatable

Purpose The analyzer slider is used to set the polarization contrast technique.

Position The analyzer slider is inserted into the 12x46 slot of the intermediate plate for analyzer slider 12x46 mounted between stand and tube.

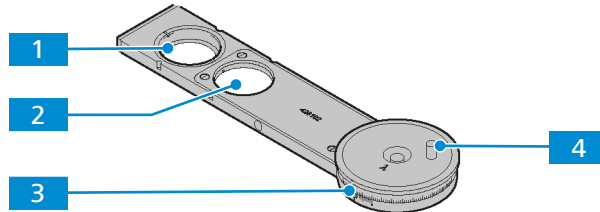

Fig. 37: Analyzer slider TL/RL, with lambda plate, 360° rotatable

- | | |
|-------------------------|--|
| 1 Empty position | 2 Analyzer and lambda plate |
| 3 Angle scale | 4 Handle to rotate the lambda plate |

10.4.3 Analyzer Slider TL/RL with Lambda Plate, each Rotatable +/- 10°

Purpose The analyzer slider is used to set the polarization contrast technique.

Position The analyzer slider is inserted into the 12x46 slot of the intermediate plate for analyzer slider 12x46 mounted between stand and tube.

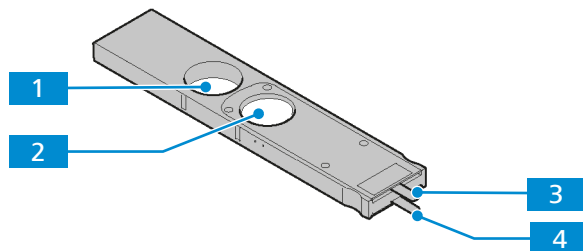

Fig. 38: Analyzer slider TL/RL with lambda plate, each rotatable +/- 10°

- | | |
|--|--|
| 1 Empty position | 2 Analyzer and lambda plate |
| 3 Handle for adjusting the lambda plate | 4 Handle for adjusting the analyzer |

10.5 Polarizers

10.5.1 Polarizer D, Fixed, Removable

Purpose The polarizer for transmitted light is used to polarize the light of the transmitted light source. The polarizer can be swivelled into or out of the beam path using the handle.

Position The polarizer is mounted on the bottom of the condenser carrier.

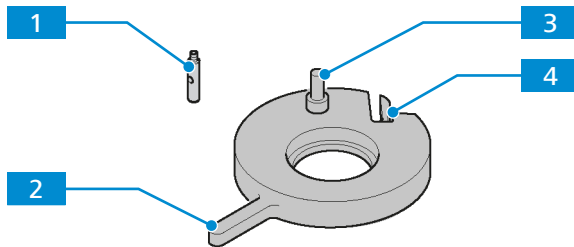

Fig. 39: Polarizer D, fixed, removable

1 Locking pin

2 Handle of the polarizer for swivelling in/out

3 Holding pin

4 Locking clamp

10.5.2 Polarizer D, 90°, Rotatable, Removable

Purpose The polarizer for transmitted light is used to polarize the light of the transmitted light source. The polarizer can be swivelled into or out of the beam path using the handle.

Position The polarizer is mounted on the bottom of the condenser carrier.

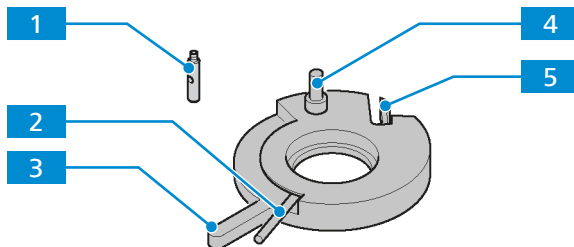

Fig. 40: Polarizer D, 90°, rotatable, removable

1 Locking pin

2 Lever for rotating the polarizer

3 Handle of the polarizer for swivelling in/out

4 Holding pin

5 Locking clamp

10.5.3 Polarizer, Fixed, with Lambda Plate, Rotatable

Purpose The polarizer for transmitted light is used to polarize the light of the transmitted light source. The polarizer can be swivelled into or out of the beam path using the handle.

Position The polarizer is mounted on the bottom of the condenser carrier.

Polarizer and lambda plate can be swivelled in/out separately.

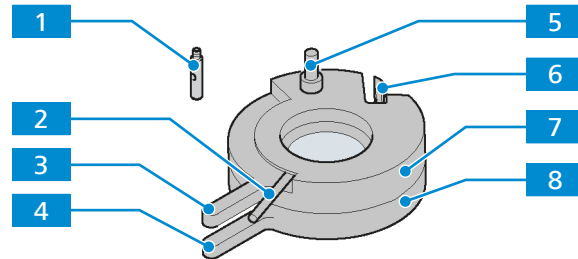

Fig. 41: Polarizer, fixed, with lambda plate, rotatable

- | | |
|---|--|
| 1 Locking pin | 2 Lever for rotating the lambda plate |
| 3 Handle of the lambda plate for swivelling in/out | 4 Handle of the polarizer for swivelling in/out |
| 5 Holding pin | 6 Locking clamp |
| 7 Lambda plate, rotatable by 90° | 8 Polarizer |

10.5.4 Polarizer, Rotatable, with Color Filter Carrier

Purpose The polarizer for transmitted light is used to polarize the light of the transmitted light source. With the help of the color filter carrier optical filter elements can be placed in the beam path. The polarizer and the filter carrier can be swivelled into or out of the beam path using the handle.

Position The polarizer with filter carrier is mounted on the bottom of the condenser carrier.

Polarizer and filter carrier can be swivelled in/out separately.

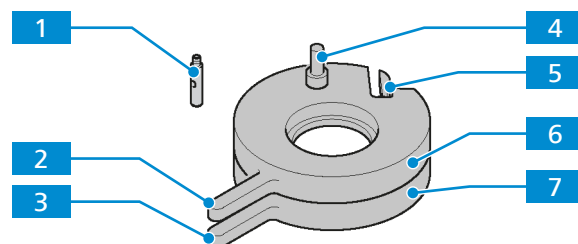

Fig. 42: Polarizer, rotatable, with color filter carrier

- | | |
|---|--|
| 1 Locking pin | 2 Handle of the polarizer for swivelling in/out |
| 3 Handle of the color filter carrier | 4 Holding pin |
| 5 Locking clamp | 6 Polarizer |
| 7 Color filter carrier | |

10.5.5 Circular Polarizer D

Purpose The polarizer for transmitted light is used to polarize the light of the transmitted light source. The polarizer can be swivelled into or out of the beam path using the handle.

Position The polarizer is mounted on the bottom of the condenser carrier.

Upper part and lower part of the polarizer can be swivelled in/out separately.

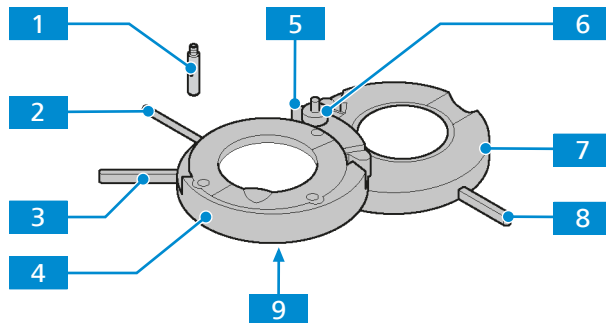

Fig. 43: Circular polarizer D

- | | |
|--|---|
| 1 Locking pin | 2 Lever for rotating the lambda 4/plate, 90° possible |
| 3 Handle of the upper part of the polarizer for swivelling in/out | 4 Lambda/4 plate in the upper part of the circular polarizer |
| 5 Locking clamp | 6 Holding pin |
| 7 Lower part of the circular polarizer | 8 Handle of the lower part of the circular polarizer for swivelling in/out |
| 9 Adjustment slit (2x) | |

10.5.6 Low-power System for Objectives 2.5x/4x

Purpose The low-power system is for full display field illumination when using an objective with a weak magnification factor (2.5x–4x) in combination with the Condenser 0.9/1.25 H.

Position The low-power system is mounted behind the condenser carrier.

Function It can be centered and remains swivelled into the beam path for as long as the respective objective is in use.

The illumination of weak objective magnifications can be centered with the centering screws. For this purpose, the condenser should be centered on the other objectives without the low-power system.

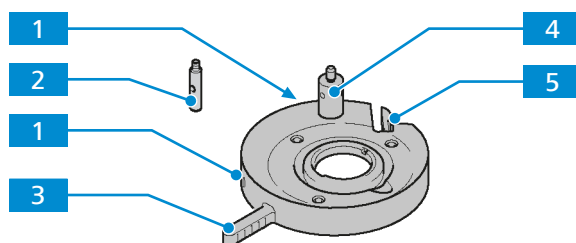

Fig. 44: Low-power system for objectives 2.5x/4x

- | | |
|---|----------------------|
| 1 Centering screw (2x) | 2 Locking pin |
| 3 Handle of the low-power system for swivelling in/out | 4 Holding pin |
| 5 Locking clamp | |

10.5.6.1 Assembling and Centering the Low-power System

Info

The low-power system can be used only in combination with the condenser 0.9/1.25.

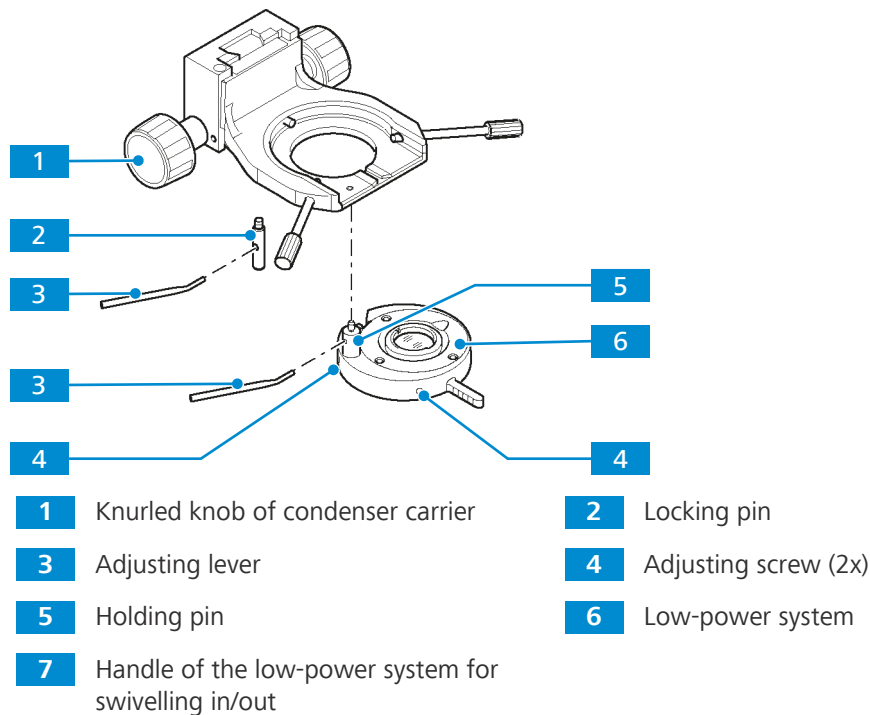

Parts and Tools  2 x Hex key, 1.5 mm

- Procedure**
1. Lift the condenser carrier together with its knurled knob **1** upwards as far as it will go.
 2. Hold the low-power system **6** parallel to the underside of the condenser carrier and screw the holding pin **5** of the low-power system with the angled adjusting lever **3** into the front left threaded hole below the condenser carrier as far as it will go.
 3. Screw the locking pin **2** with the adjusting lever as far as it will go into the rear threaded hole of the condenser carrier.
 4. Swivel the low-power system into the beam path using the handle **7**.
→ Make sure that it is securely engaged.
 5. Switch on the microscope.
 6. Set transmitted light illumination.
 7. Open the aperture diaphragm and luminous-field diaphragm completely.
 8. Adjust both adjustment screws **4** until the field of vision is optimally illuminated.

10.5.7 Color Filter Carrier 3x for Filter d=32mm

Purpose With the help of the color filter carrier optical filter elements can be placed in the beam path. The filter carriers can be swivelled into or out of the beam path using the handle.

Position The color filter carrier is mounted on the bottom of the condenser carrier. The three filter carriers can be swivelled in/out separately.

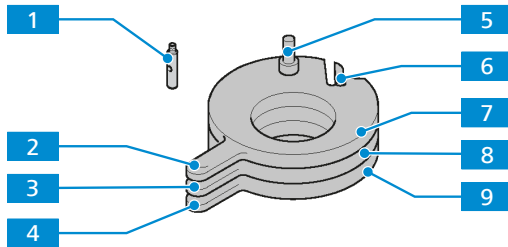

Fig. 45: Color filter carrier 3x for filter d=32mm

- | | |
|--|---|
| 1 Locking pin | 2 Handle of the first filter carrier for swivelling in/out |
| 3 Handle of the second filter carrier for swivelling in/out | 4 Handle of the third filter carrier for swivelling in/out |
| 5 Holding pin | 6 Locking clamp |
| 7 First filter carrier | 8 Second filter carrier |
| 9 Third filter carrier | |

10.5.8 Assembling Polarizer or Color Filter Carrier onto the Condenser Carrier

The following polarizers or the filter carrier can be installed on the condenser carrier:

- Polarizer D, fixed, removable
- Polarizer D, 90° rotary, removable
- Polarizer, rotary, with color filter carrier
- Polarizer, fixed, with lambda plate, rotary
- Circular polarizer D, fixed, with rotary lambda/4 plate
- Color filter carrier 3x for filter d=32 mm

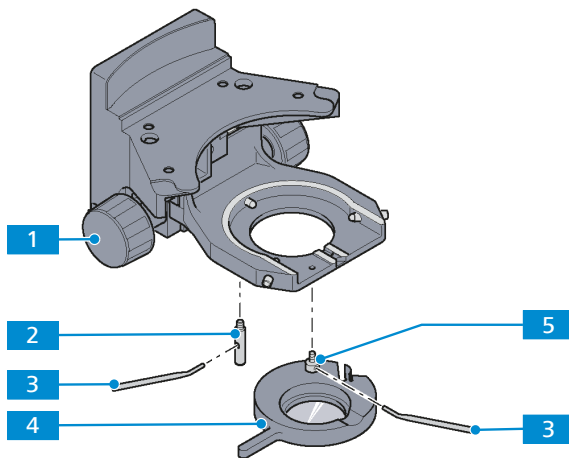

- | | |
|--|----------------------|
| 1 Knurled knob of condenser carrier | 2 Locking pin |
| 3 Adjusting lever | 4 Polarizer |
| 5 Holding pin | |

- Procedure**
1. Lift the condenser carrier upwards as far as it will go using the knurled knob **1**.
 2. Hold the polarizer **4** or filter carrier parallel to the underside of the condenser carrier and screw the holding pin **5** of the polarizer with the angled adjusting lever **3** into the front left threaded hole below the condenser carrier as far as it will go.
 3. Screw the locking pin **2** with the adjusting lever as far as it will go into the rear threaded hole of the condenser carrier.

Proceed in the reverse order for removal.

10.6 DIC Slider C 6x20

Purpose The DIC slider is used to set the DIC contrast technique.

Position The DIC slider is inserted into the 6x20 slot above the nosepiece.

The DIC slider is available in two versions:

- DIC Slider C 6x20 for objectives EC Epiplan 5x - 20x
- DIC Slider C 6x20 for objectives EC Epiplan 50x - 100x

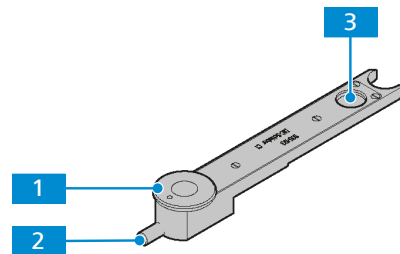

Fig. 46: DIC Slider C 6x20

- | | |
|------------------------|------------------------|
| 1 Setting wheel | 2 Setting screw |
| 3 DIC prism | |

10.7 Condenser, achromatic-aplanatic 0.9 BF DF PhC DIC

Purpose Condensers are used to optimize the transmitted light illumination. The condenser is usable for brightfield, darkfield, phase contrast and DIC applications.

Position The condenser is mounted on the condenser carrier of the stand.

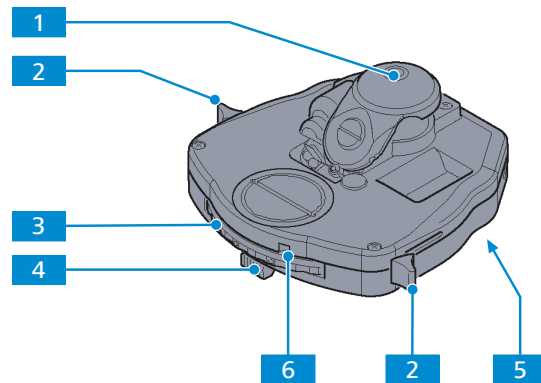
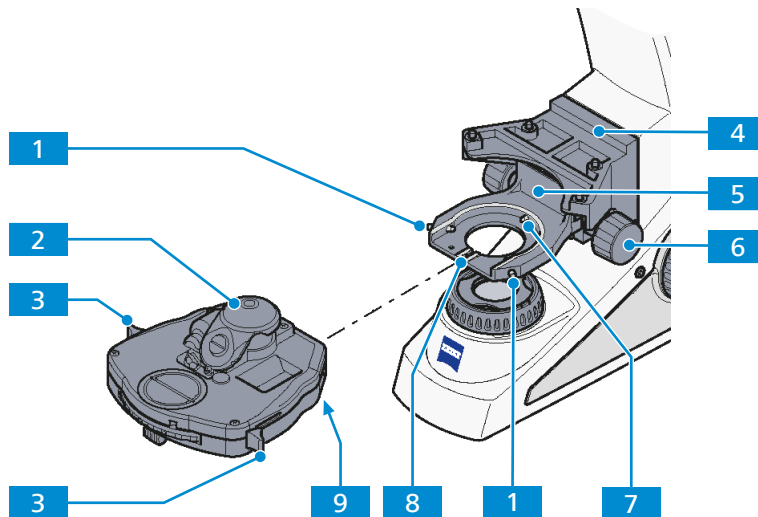

Fig. 47: Condenser, achromatic-aplanatic 0.9 BF DF PhC DIC

- | | |
|---|---|
| 1 Front lens | 2 Lever for switching the front lens in/out (left/right) |
| 3 Knurled ring for adjusting the position of the 5-positions turret disk | 4 Sliding control for setting the aperture diaphragm |
| 5 Dovetail ring mount | 6 Display field of the adjusted turret disk position |

10.7.1 Assembling the Condenser, achromatic-aplanatic 0.9 BF DF PhC DIC



- | | |
|--|--|
| 1 Centering screw (left/right) | 2 Front lens |
| 3 Lever for swivelling the front lens in/out (left/right) | 4 Stage carrier |
| 5 Condenser carrier | 6 Knurled knob for vertical adjustment of the condenser carrier |
| 7 Mainspring | 8 Groove |
| 9 Screwed stud bolt | |

- Procedure**
- Carefully move the stage carrier **4** with the focusing drive to the upper stop position.
NOTICE Make sure that the stage does not collide with the objective.

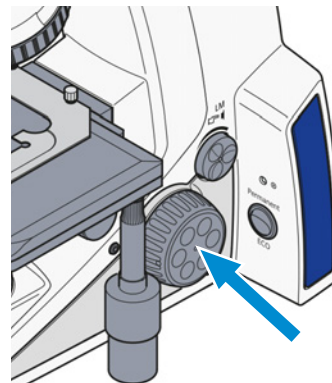

- Swivel out the front lens **2** on the condenser using the lever **3**.
- Unscrew both centering screws **1** on the condenser carrier **5** until their ends are no longer visible.
- Using the knurled knob **6** for vertical adjustment, push the condenser carrier down as far as it will go.
NOTICE If using a low-power system, make sure that this does not come to rest on the luminous-field diaphragm.
- Insert the condenser between the condenser carrier and the stage carrier **4**. In doing so, align the screwed stud bolt **9** on the underside of the condenser with the groove **8** of the condenser carrier.
- Press the condenser with the dovetail ring against the mainspring **7** of the condenser carrier until the condenser sits horizontally on the condenser carrier.
- Screw in the centering screws **1** until they engage with the dovetail ring of the condenser.

10.7.2 Centering the Darkfield Diaphragm of the Condenser

Parts and Tools  2 x Hex key, 1.5 mm

- Prerequisite**
- ✓ A suitable condenser with modulator disk is installed.
 - ✓ The illumination is adjusted for transmitted light brightfield microscopy.

- Procedure**
1. Set the modulator disks to position D (or DF = darkfield).
 2. Remove one eyepiece from the binocular tube or replace it with the auxiliary microscope.
 3. Observe the exit pupil of the objective.
 4. Turn the two centering screws, until the exit pupil of the objective appears homogeneously dark.

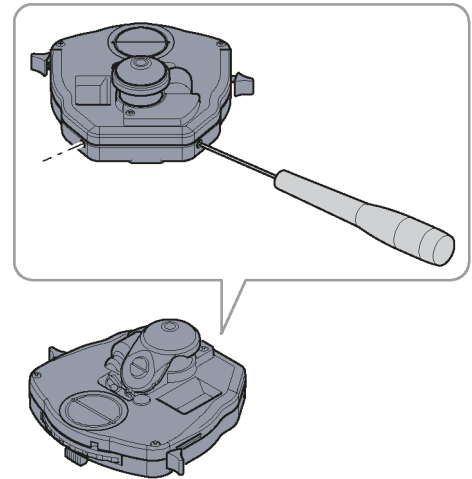

5. Insert the eyepiece.

10.7.3 Centering the Annular Phase Diaphragm of the Condenser

Parts and Tools  2 x Hex key, 1.5 mm

- Prerequisite**
- ✓ A suitable condenser with modulator disk is installed.
 - ✓ The illumination is adjusted for transmitted light brightfield microscopy.

- Procedure**
1. Set the modulator disks to position **Ph** (phase contrast).
 2. Remove one eyepiece from the binocular tube or replace it with the auxiliary microscope.
 3. Observe the exit pupil of the objective.
 4. Check the centering and the overlap of the lighter annular phase diaphragm (in the condenser) with the darker phase ring (in the objective). Both rings must be centered and overlapping

B

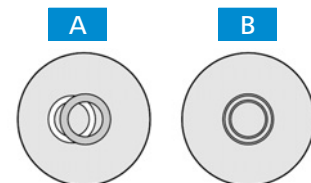

5. If the overlap is not exact **A**, recenter the lighter annular diaphragm.

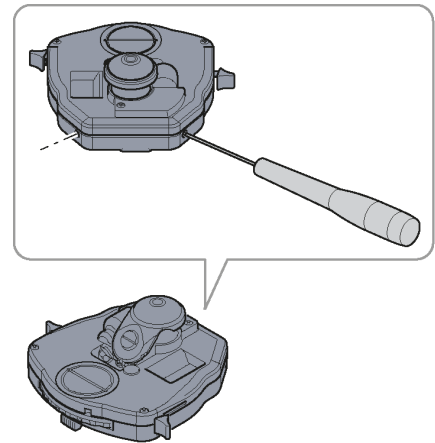

6. Remove the auxiliary microscope and replace the eyepiece.

10.8 Light Source for Transmitted Light

⚠ DANGER

Electric shock due to live parts

When the microscope is still switched on, coming in contact with live parts can lead to electric shock or burn.

- ▶ Switch off the microscope prior to opening or cleaning.
- ▶ Disconnect live parts from the power supply.

⚠ CAUTION

Burning hazard due to hot light sources

Light sources can become hot during processing.

- ▶ Allow it to cool down at least 15 min.

10.8.1 Removing the Cover (Transmitted Light Source)

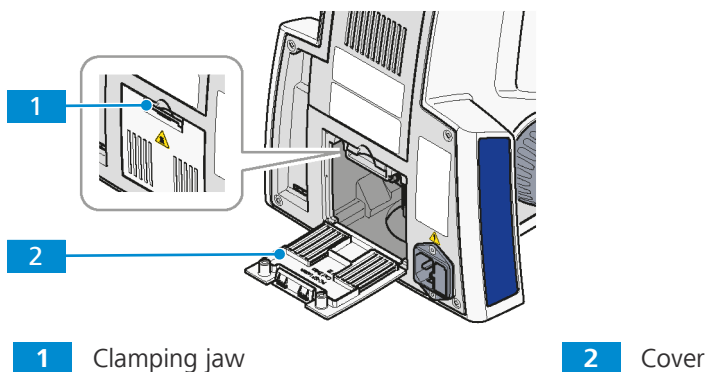

Prerequisite ✓ The microscope is switched off and disconnected from the mains.

- Procedure**
1. Press the clamping jaw **1** on the cover downwards.
 2. Swing the cover **2** down.
 3. Remove it from the retaining channels on the stand.
 4. Set the cover aside.

Proceed in the reverse order for installing.

10.8.2 Exchanging the Halogen Lamp

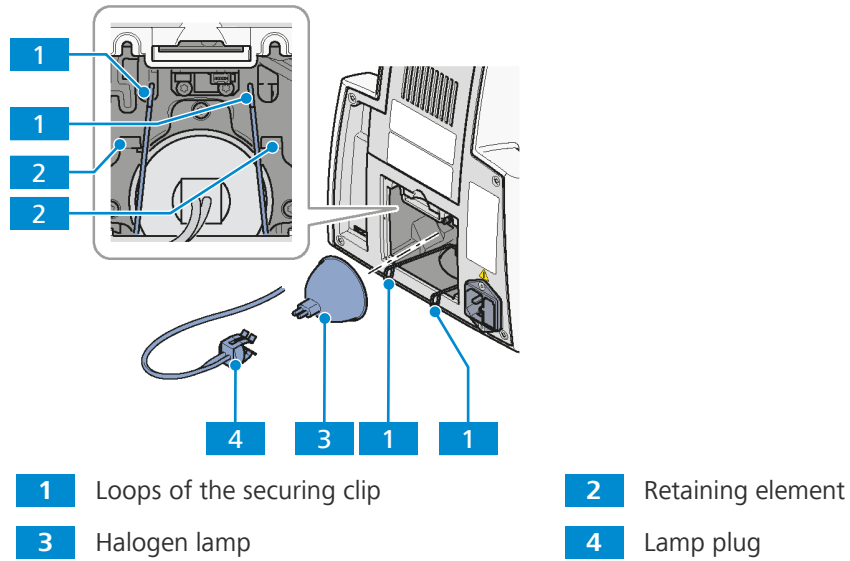

Prerequisite ✓ The cover is removed, see *Removing the Cover (Transmitted Light Source)* [▶ 126].

- Procedure**
1. Remove the lamp plug **4** from the halogen lamp **3**.
 2. Press the loops **1** on the securing clip of the lamp holder together and swing them out to the front.
 3. Remove the old halogen lamp.
 4. Position the new lamp with the lower front edge between the contact surface and securing clip.
 5. Lift the securing clip of the lamp holder with the lamp until they are completely enclosed in the lamp holder.
 - In doing so, slightly press the ends of the securing clip together and guide past the two upper retaining elements **2**.
 - Release the pressure until the clamping bracket opens and engages on both sides in the retaining elements.
 6. Check that the lamp is seated correctly.
 7. Push the lamp plug onto the pins of the lamp.
 8. Ensure that it engages properly to avoid bending the pins.
 9. Insert the cable of the lamp plug into the stand so that it is not damaged when the cover is attached.
 10. Insert the cover, see *Removing the Cover (Transmitted Light Source)* [▶ 126].

10.8.3 Exchanging the LED Light Source

Exchanging the LED light source is done in the following steps:

- removing the cover [▶ 126]
- removing the LED light source including adapter [▶ 129]
- exchanging the LED light source in the adapter [▶ 129]
- installing the LED light source including adapter [▶ 129]
- installing the cover [▶ 126]

10.8.3.1 Removing the LED Light Source

⚠ CAUTION

Eye damage or skin irritation due to hazardous light emission

The light source belongs to Risk Group 2 as specified in IEC 62471 and emits LED radiation and UV radiation. Eye damage or skin irritation may result from exposure.

- ▶ Never look directly into the light-emitting aperture of the light source.
- ▶ Avoid exposure of skin to the radiation. Use suitable protective equipment/protective clothing if required.
- ▶ Before installing or removing the light source always make sure it is switched off.

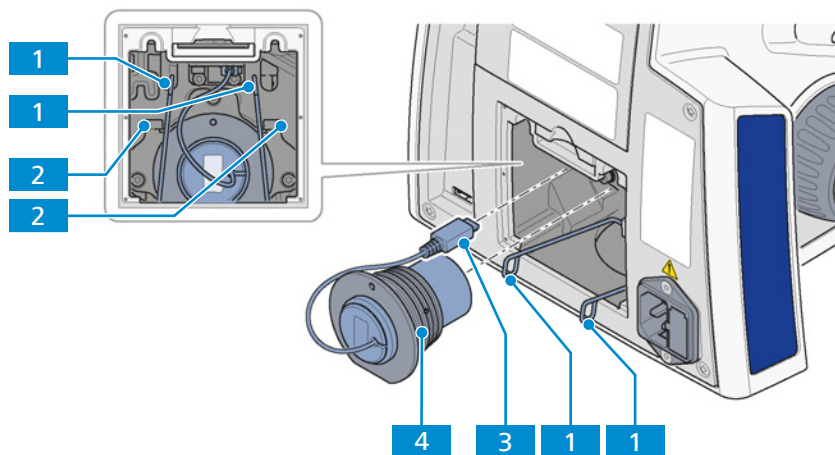

1 Loops on the securing clips

2 Retaining element

3 Illuminator plug

4 LED light source with adapter

Prerequisite ✓ The cover is removed, see *Removing the Cover (Transmitted Light Source)* [▶ 126].

- Procedure**
1. Remove the LED light source plug **3** from the connector of the stand.
 2. Press the loops **1** on the securing clip of the lamp holder together and swing them out to the front.
 3. Pull the old LED light source with adapter **4** out of the holding tube.

10.8.3.2 Exchanging the LED Light Source in the Adapter

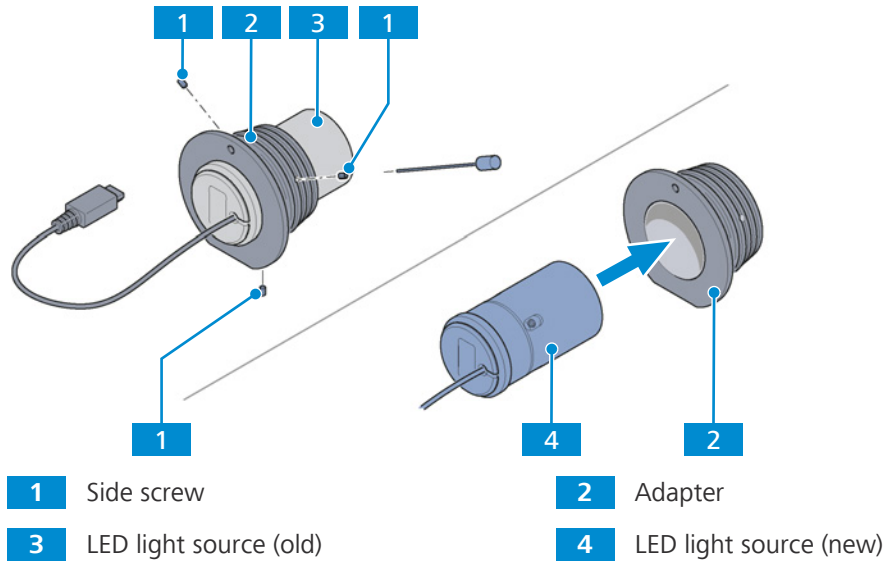

Parts and Tools Hex Key, 2.5 mm

- Procedure**
1. Loosen the three side screws **1**.
 2. Remove the old LED light source **3** from the adapter **2**.
 3. Insert the new LED light source **4** into the adapter.
 4. Tighten the three side screws on the adapter.

10.8.3.3 Assembling the LED Light Source

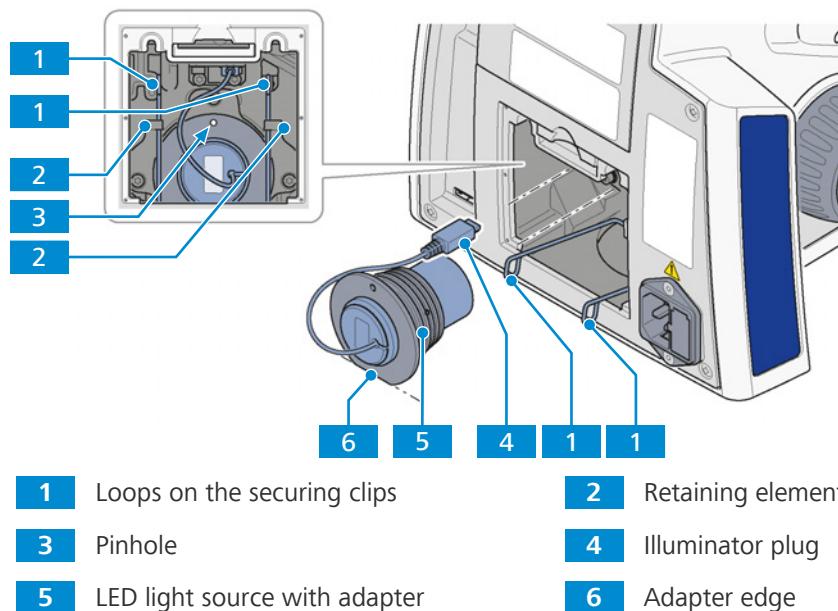

- Procedure**
1. Insert the new LED light source with the adapter **5** into the holding tube up to the stop.
 2. Position the new LED light source with the pinhole **3** at the top, or with the adapter edge **6** aligned between the contact surface and securing clips.
 3. Plug the light source plug **4** into the connector of the stand.

4. Lift the securing clips of the lamp holder until they are completely enclosed in the lamp holder.
 - In doing so, slightly press the loops of the securing clips **1** together and guide past the two upper retaining elements **2**.
 - Release the pressure until the clamping bracket opens and engages on both sides in the retaining elements.
5. Insert the cover, see *Removing the Cover (Transmitted Light Source)* [▶ 126].

10.9 Light Source for Reflected Light

⚠ DANGER

Electric shock due to live parts

When the microscope is still switched on, coming in contact with live parts can lead to electric shock or burn.

- ▶ Switch off the microscope prior to opening or cleaning.
- ▶ Disconnect live parts from the power supply.

⚠ CAUTION

Burning hazard due to hot light sources

Light sources can become hot during processing.

- ▶ Allow it to cool down at least 15 min.

10.9.1 Removing the Cover (Reflected Light Source)

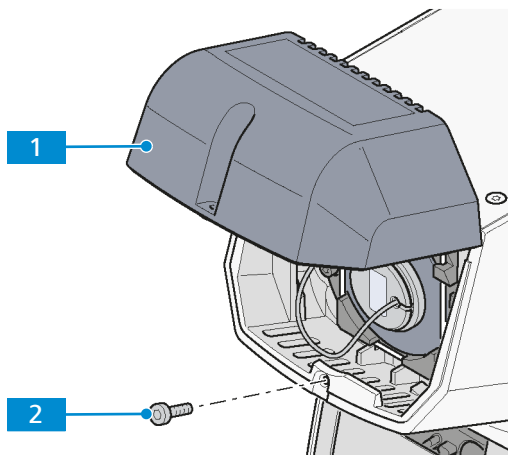

1 Cover

2 Clamping screw

Parts and Tools  Hex Key, 3.0 mm

Prerequisite  The microscope is switched off and disconnected from the mains.

- Procedure**
1. Unscrew the clamping screw **2** in the cover **1**.
 2. Swing the cover slightly upwards and apply pressure from below to remove it from the stand.

Proceed in the reverse order for installing.

10.9.2 Exchanging the Halogen Lamp

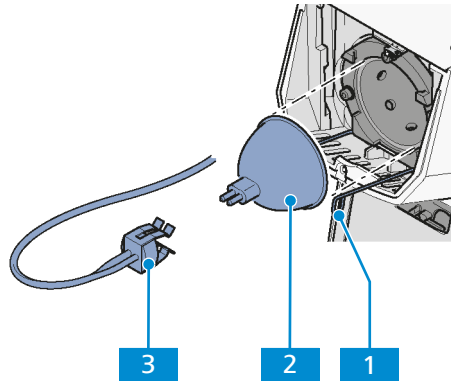

1 Loops of the securing clip

2 Halogen lamp

3 Lamp plug

Prerequisite ✓ The cover is removed, see *Removing the Cover (Reflected Light Source)* [[▶ 130](#)].

- Procedure**
1. Remove the lamp plug **3** from the halogen lamp **2**.
 2. Press the loops on the securing clip **1** of the lamp holder together and swing them out to the front.
 3. Remove the old halogen lamp.
 4. Position the new halogen lamp on the contact surface of the lamp holder (the lamp will be held securely by the groove).
 5. Press the securing clips on both sides of the lamp holder and swing them upwards until the securing clips are seated against the halogen lamp.
 6. Slowly release the securing clips so that they open and engage in the retaining elements to the right and left.
 7. Check that the halogen lamp is correctly seated.
 8. Push the lamp plug onto the pins of the lamp. Ensure that it engages properly to avoid bending the pins.
 9. Insert the cable of the lamp plug into the stand so that it is not damaged when the cover is attached.
 10. Insert the cover, see *Removing the Cover (Reflected Light Source)* [[▶ 130](#)].

10.9.3 Exchanging the LED Light Source

exchanging the LED light source is done in the following steps:

- *removing the cover* [[▶ 130](#)]
- *removing the LED light source including adapter* [[▶ 132](#)]
- *exchanging the LED light source in the adapter* [[▶ 133](#)]
- *assembling the LED light source including adapter* [[▶ 133](#)]
- *assembling the cover* [[▶ 130](#)]

10.9.3.1 Removing the LED Light Source

⚠ CAUTION

Eye damage or skin irritation due to hazardous light emission

The light source belongs to Risk Group 2 as specified in IEC 62471 and emits LED radiation and UV radiation. Eye damage or skin irritation may result from exposure.

- ▶ Never look directly into the light-emitting aperture of the light source.
- ▶ Avoid exposure of skin to the radiation. Use suitable protective equipment/protective clothing if required.
- ▶ Before installing or removing the light source always make sure it is switched off.

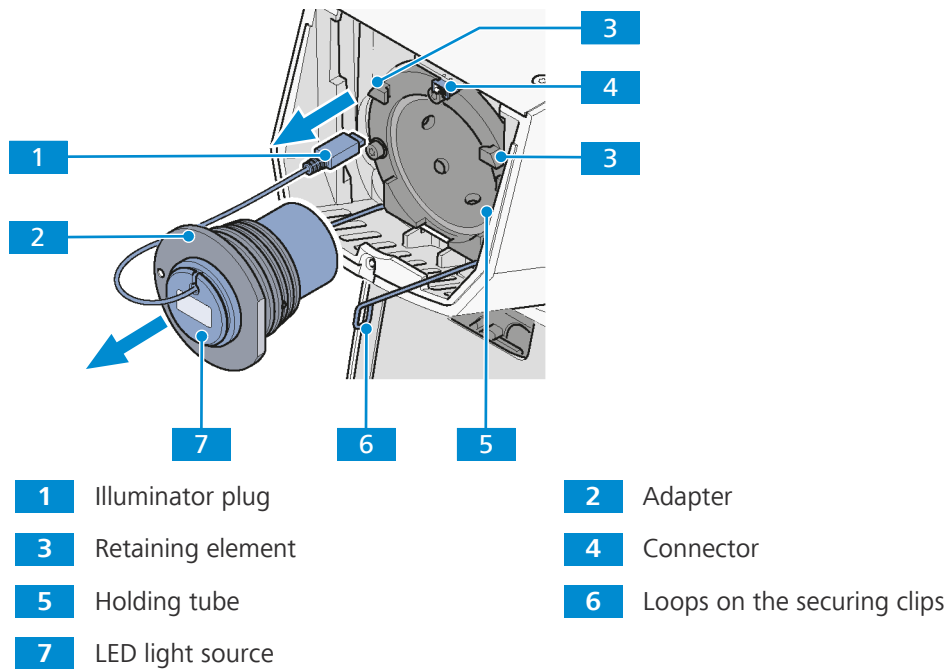

Prerequisite ✓ The cover is removed, see *Removing the Cover (Reflected Light Source)* [▶ 130].

- Procedure**
1. Press the loops on the securing clip of the lamp holder together and swing them out to the front.
 2. Remove the LED light source plug from the connector of the stand.
 3. Pull the old LED light source with adapter out of the holding tube.

10.9.3.2 Exchanging the LED Light Source in the Adapter

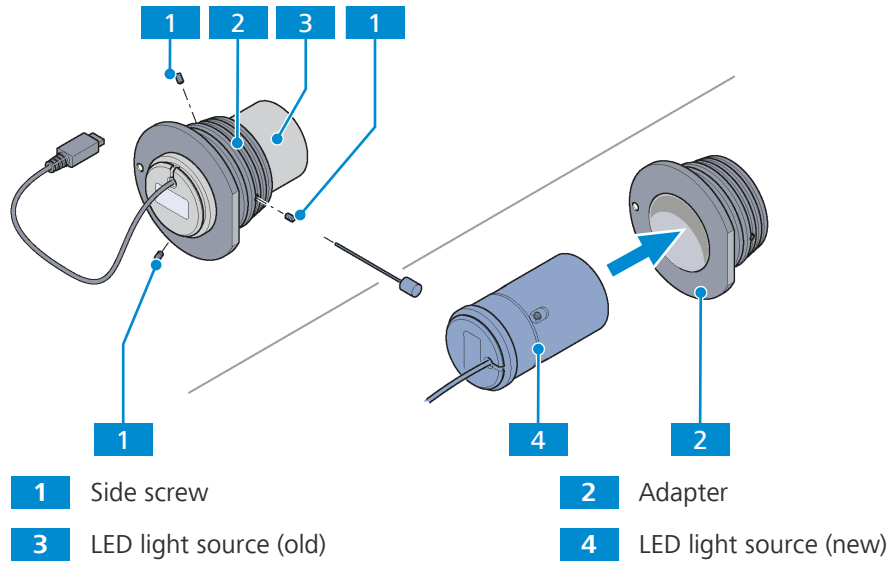

Parts and Tools 🔧 Hex Key, 2.5 mm

- Procedure**
1. Loosen the three side screws **1**.
 2. Remove the old LED light source **3** from the adapter **2**.
 3. Insert the new LED light source **4** into the adapter.
 4. Tighten the three side screws on the adapter.

10.9.3.3 Assembling the LED Light Source

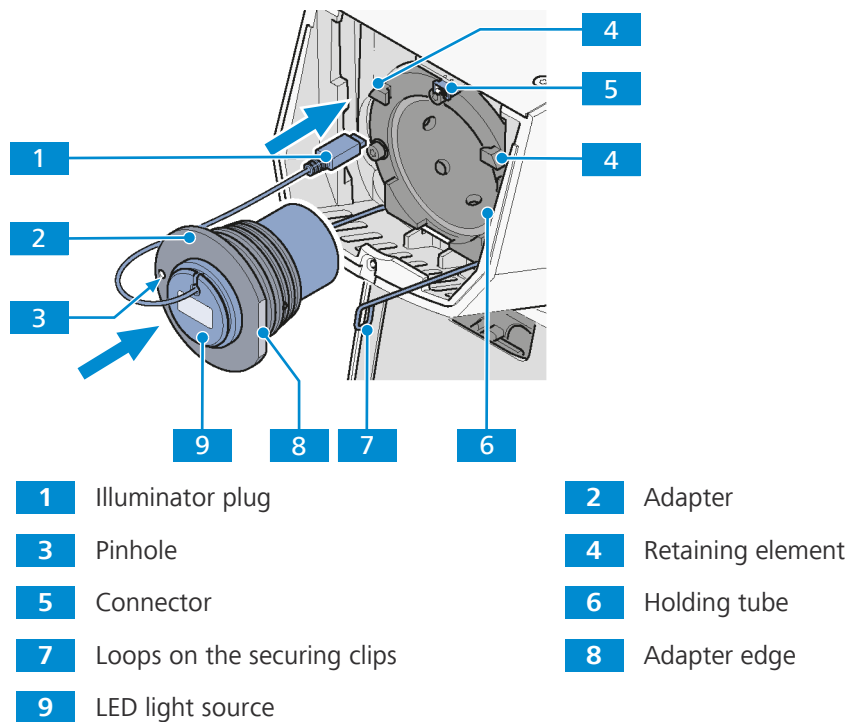

- Procedure**
1. Insert the new LED light source **9** with the adapter **2** into the holding tube up to the stop.
 2. Position the new LED light source with the pinhole **3** at the left, or with the adapter edge **8** aligned to the right.

3. Plug the light source plug **1** into the connector of the stand **5**.
4. Lift the securing clips of the lamp holder until they are completely enclosed in the lamp holder.
 - In doing so, slightly press the loops of the securing clips **7** together and guide past the two retaining elements **4**.
 - Release the pressure until the clamping bracket opens and engages on both sides in the retaining elements.
5. Insert the cover, see *Removing the Cover (Reflected Light Source)* [▶ 130].

10.9.4 Exchanging the LED Modules of the Fluorescence Light Source

Exchanging the LED modules is done in the following steps:

- *removing the cover* [▶ 130]
- *removing the module holder* [▶ 134]
- *exchanging the LED modules* [▶ 135]
- *assembling the module holder* [▶ 136]
- *assembling the cover* [▶ 130]

10.9.4.1 Removing the Module Holder

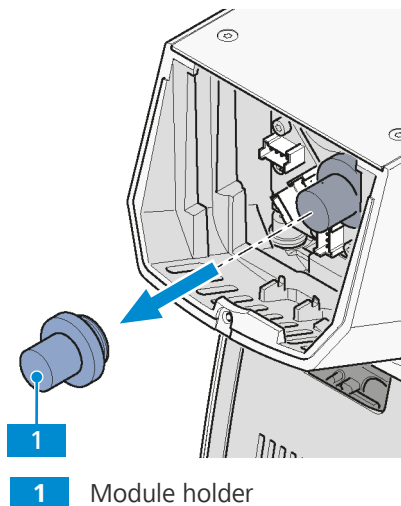

Prerequisite ✓ The cover is removed, see *Removing the Cover (Reflected Light Source)* [▶ 130].

Procedure 1. Unscrew the module holder **1** from the stand socket.

10.9.4.2 Exchanging the LED Modules

⚠ WARNING

Skin or eye injury due to hazardous light emission

The light source belongs to Risk Group 3 as specified in IEC 62471 and emits LED radiation and UV radiation. Skin or eye injury can result from the exposure.

- ▶ Avoid any eye and skin exposure to the light-emitting aperture of the light source.
- ▶ Avoid exposure of skin to the radiation. Use suitable protective equipment/protective clothing if required.
- ▶ Before installing or removing the light source always make sure it is switched off.

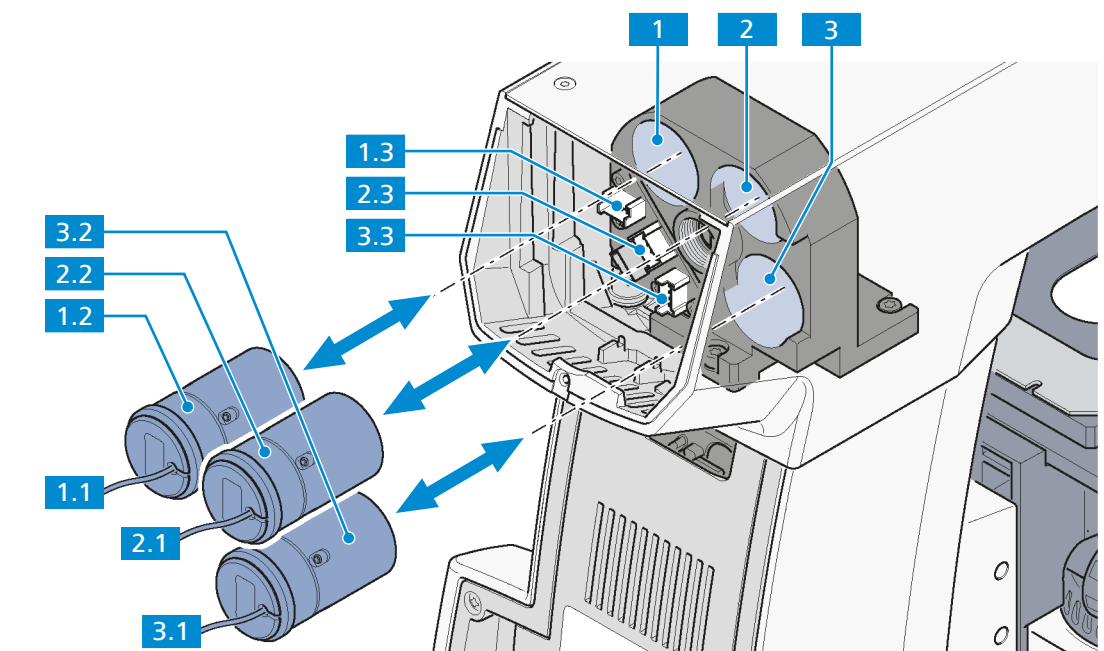

1 LED tube, position 1

1.2 LED module 1

2 LED tube, position 2

2.2 LED module 2

3 LED tube, position 3

3.2 LED module 3

1.1 Plug of LED module 1

1.3 Connector, position 1

2.1 Plug of LED module 2

2.3 Connector, position 2

3.1 Plug of LED module 3

3.3 Connector, position 3

Procedure

1. Unplug the module plugs (**1.1**, **2.1**, **3.1**) from the connectors (**1.3**, **2.3**, **3.3**) of the stand socket.
2. Remove the old LED modules (**1.2**, **2.2**, **3.2**) out of the LED tubes of the stand socket.
3. Insert the new LED modules into the LED tubes (**1**, **2**, **3**) up to the stop.
4. Ensure that the modules are inserted in the right holding positions.
5. Plug the module plugs into the connectors of the stand socket.
6. Ensure that the plugs are connected to the right connectors.

Info

The LED positions **1**, **2** and **3** correspond to the UV, B and G labels on the right side of the Axiolab 5 Bio-TL/FL stand model.

Info

Due to the limited space in the LED module socket, the LED module in position **2** needs to be removed first when replacing the LED module in position **3**.

10.9.4.3 Assembling the Module Holder

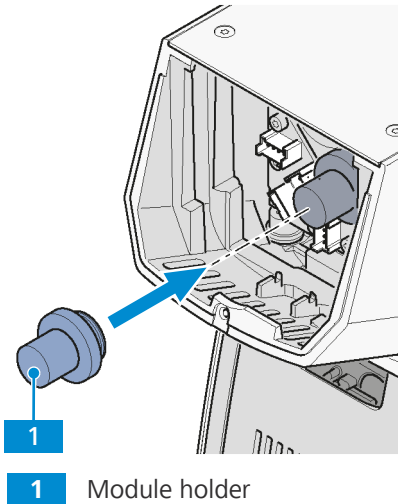

- Procedure**
1. Screw the module holder **1** into the stand socket to fix the modules in place.
 2. Insert the cover, see *Removing the Cover (Reflected Light Source)* [▶ 130].

10.10 Axiocam 202 Mono/208 Color

Purpose The camera is used to snap photos or the microscopic image.

Position The Axiocam 202 mono or Axiocam 208 color is mounted on the camera port of the photo tube..

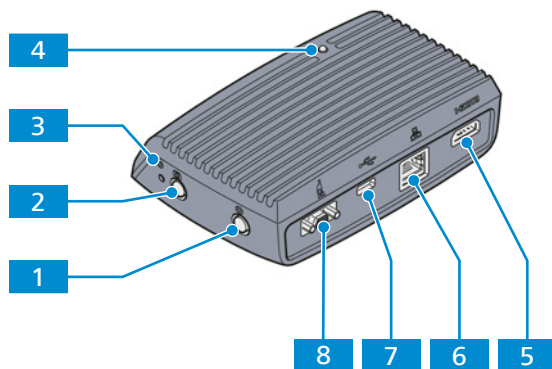



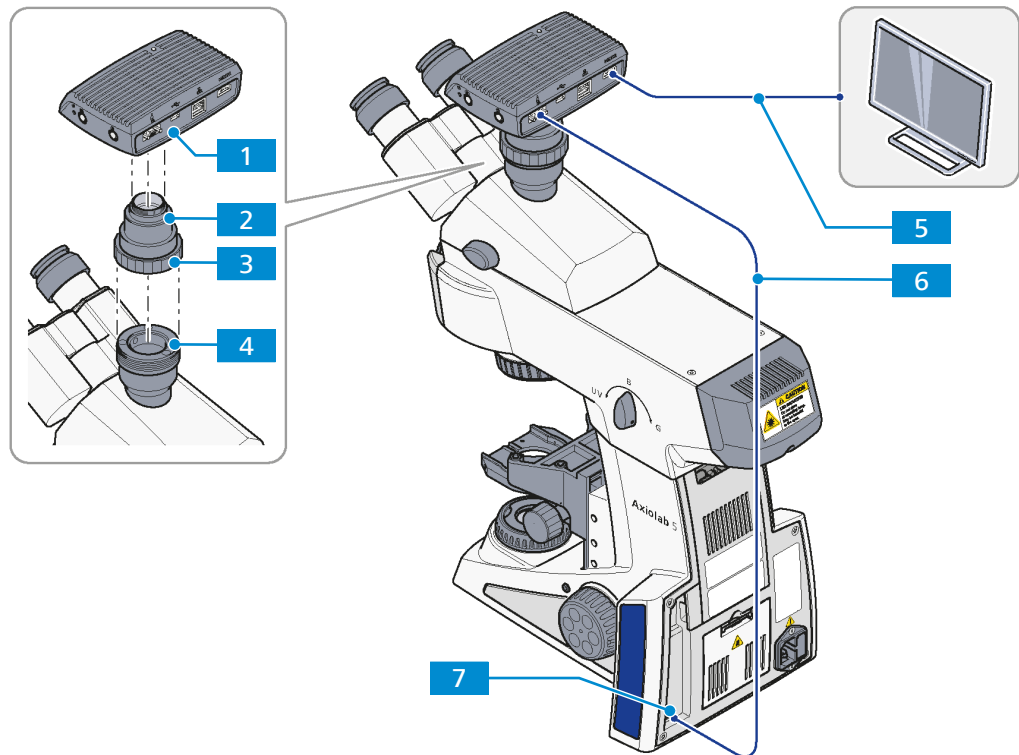

Fig. 48: Axiocam 202 mono/208 color

- | | |
|--|---|
| 1 OSD menu button | 2 Image/video capture button |
| 3 Camera factory reset button | 4 Status LED |
| 5 HDMI port for image data transfer to a monitor, TV or projector | 6 Gigabit Ethernet port (RJ45) for communication and image transfer |
| 7 Port for camera control and image transfer (USB 3.0) | 8 Port for power supply and communication to the microscope stand (via Commercial Micro-D cable) |

10.10.1 Assembling the Axiocam 202 mono or Axiocam 208 color

- Parts and Tools**
-  C-mount camera adapter
 -  USB (Commercial Micro-D) cable (USB 2.0)
 -  HDMI cable



- | | | | |
|----------|-----------------|----------|--------------------------------|
| 1 | Axiocam | 2 | C-mount camera adapter |
| 3 | Ring nut | 4 | Camera port |
| 5 | HDMI cable | 6 | USB (Commercial Micro-D) cable |
| 7 | Stand connector | | |

- Procedure**
1. Mount the C-mount camera adapter **2** on the Axiocam **1**.
 2. Attach the Axiocam with the adapter to the camera port **4** of the tube.
 3. Orient the camera to the stand and fix it in position by tightening the ring nut **3**.
 4. Connect the camera to the stand connector **7** via the USB (Commercial Micro-D) cable **6**.
 5. Connect the camera to an external monitor via an HDMI cable **5**.
 6. Alternatively, connect the camera to a WLAN router, USB Type-C drive or PC, see also *Operating Modes Using the Axiocam 202 mono/208 color* [[▶ 138](#)].

10.10.2 Operating Modes Using the Axiocam 202 mono/208 color

10.10.2.1 Axiocam as Standalone System

Purpose The camera is used to capture the microscopic image and store the data on the USB drive connected to the camera.

Function The camera acts as the control interface and is powered by the microscope via the USB (Commercial Micro-D power) cable.

A USB Type-C drive is included in the package and can be connected via the USB slot at the back of the camera for storing data. Then images are recorded and saved to the USB drive.

Functions of the microscope stand such as the Light Manager and encoding are automatically launched. The camera is equipped with image enhancement functions such as true color and noise reduction.

Functionality of the microscope:

- Light Manager
- Coded components
- Image enhancement (true color, noise reduction)
- Record and save images on the USB drive
- Record and save videos on the USB drive

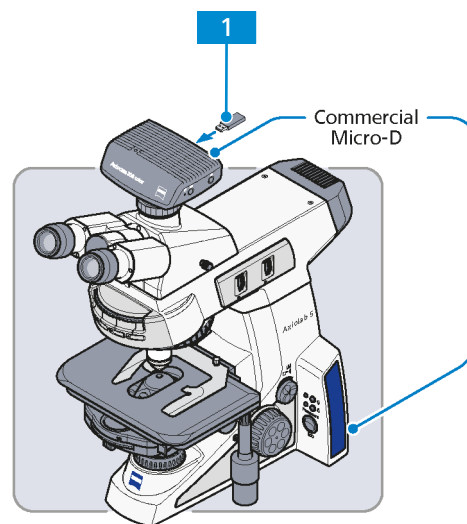

Fig. 49: Axiocam as standalone system

- 1** USB Type-C drive (included in package)

10.10.2.2 Axiocam connected to an HD monitor, TV or Projector

Purpose The camera is used to capture the microscopic image.

Function A monitor can be connected to the camera via an HDMI cable. The camera is powered by the microscope via the USB (Commercial Micro-D power) cable.

A monitor can be connected to the camera of the microscope via an HDMI cable. The camera is powered by the microscope via a USB (Commercial Micro-D power) cable. A USB hub can be connected via the USB port on the camera.

A wireless or wired mouse and keyboard can be connected to the camera via the USB hub, which together with the monitor, function as the control interface. Functions such as the Light Manager, encoding and image enhancement are automatically launched. Live images can be viewed on the monitor display and advanced features are available in the on-screen display (OSD).

When the microscope is operated together with the Colibri 3 light source, the one-key fluorescence function can be used. Images can be snapped and saved on the USB Type-C drive, which is connected via the USB hub.

Functionality of the microscope:

- Light Manager
- Coded components
- Image enhancement (true color, noise reduction)
- Observe live image on display
- Record and save image on the USB drive
- Record and save video on the USB drive
- One-key fluorescence (works only when the Axioscope is used with Colibri 3)
- Advanced features in OSD

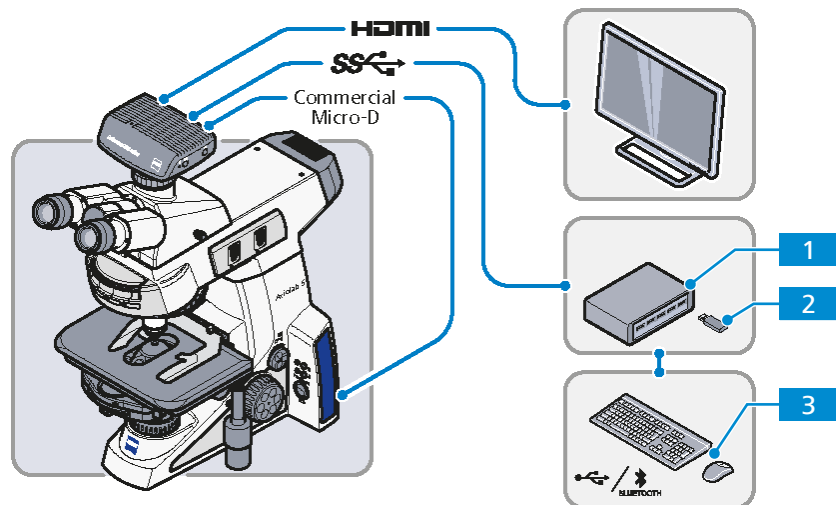

Fig. 50: Axiocam connected to an HD monitor, TV or projector

- 1** USB hub (input type C to output type A)
- 2** USB Type-C drive provided in package
- 3** Mouse, keyboard

10.10.2.3 Axiocam connected with Labscope/Matscope via a Wi-Fi Dongle

Purpose The camera is used to capture the microscopic image.

Function The camera is powered by the microscope via the USB (Commercial Micro-D power) cable.

An optional monitor can be connected to the camera via an HDMI cable.

The recommended USB Wi-Fi dongle can be connected to the camera via the USB hub.

The control interface can be a PC or portable electronic device that uses Wi-Fi.

Functions such as the Light Manager, encoding, ECO mode and image enhancement are automatically launched.

When a monitor is connected, live images can be viewed on the monitor display. Live images can also be viewed on PC or portable devices and advanced features in Labscope/Matscope are available.

Functionality of the microscope:

- Light Manager
- Coded components
- ECO mode
- Image enhancement
- Observe live images
- Record and save images via software
- One-key fluorescence (this works only with Axiolab Bio-TL/FL)
- Advanced features in Labscope/Matscope

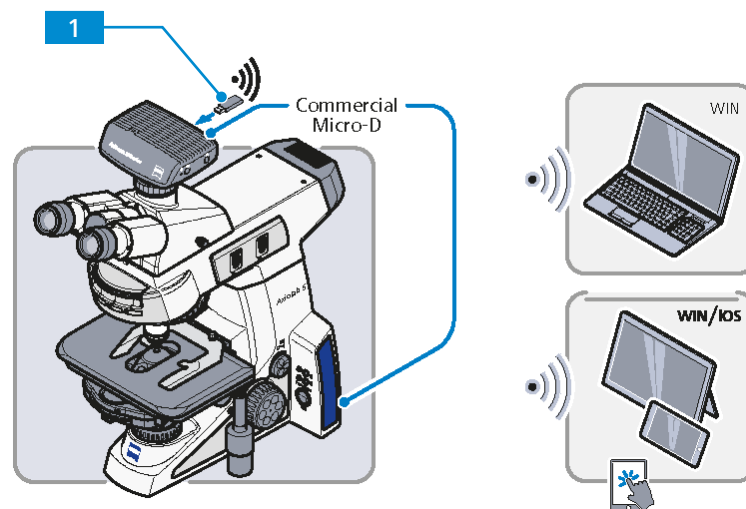

Fig. 51: Axiocam connected with Labscope/Matscope via a Wi-Fi dongle

- 1 USB Wi-Fi dongle (please see the ZEISS website for the recommended model)

10.10.2.4 Axiocam connected with Labscope/Matscope via a WLAN Router

Purpose The camera is used to capture the microscopic image.

Function The camera is powered by the microscope via the USB (Commercial Micro-D power) cable.

An optional monitor can be connected to the camera via an HDMI cable.

A router is connected to the camera via Ethernet.

The control interface can be a PC or portable electronic device controlled via Ethernet or Wi-Fi.

Functions such as the Light Manager, encoding, ECO mode and image enhancement are automatically launched.

When a monitor is connected, live images can be viewed on the monitor display. Live images can also be viewed on a PC or a portable device and advanced features in Labscope/Matscope are available.

Functionality of the microscope:

- Light Manager
- Coded components
- ECO mode
- Image enhancement
- Observe live images
- Record and save images via software
- One-key fluorescence (this works only with Axiolab Bio-TL/FL)
- Advanced features in Labscope/Matscope

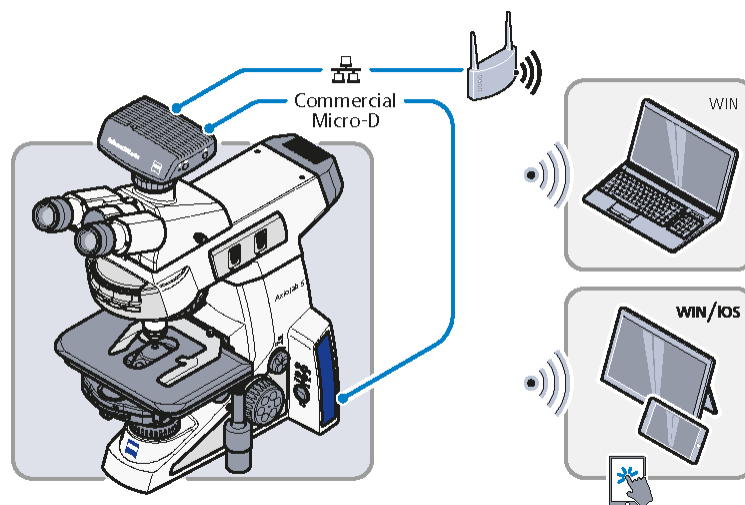

Fig. 52: Axiocam connected with Labscope/Matscope via a WLAN router

10.10.2.5 Axiocam connected with Labscope/Matscope via a USB

Purpose The camera is used to capture the microscopic image.

Function The camera is powered by the microscope via the USB (Commercial Micro-D power) cable.

An optional monitor can be connected to the camera via an HDMI cable.

A PC or Windows Surface can be connected to the camera via a USB cable.

Functions such as the Light Manager, encoding, ECO mode and image enhancement are automatically launched.

When a monitor is connected, live images can be viewed on the monitor display. Live images can also be viewed on a PC or Surface and advanced features in Labscope/Matscope are available.

Functionality of the microscope:

- Light Manager
- Coded components
- ECO mode
- Image enhancement
- Observe live images
- Record and save images via software
- One-key fluorescence (this works only with Axiolab Bio-TL/FL)
- Advanced features in Labscope/Matscope

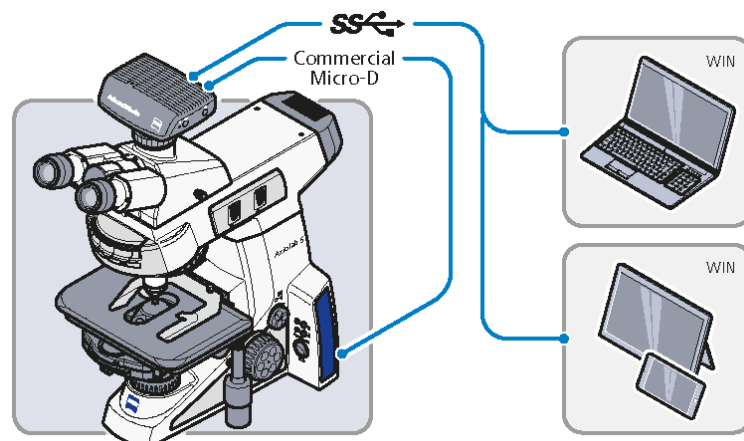

Fig. 53: Axiocam connected with Labscope/Matscope via a USB

10.10.2.6 Axiocam connected with ZEN software via a USB

Purpose The camera is used to capture the microscopic image.

Function The camera is powered by the microscope via the USB (Commercial Micro-D power) cable.

A workstation can be connected to the camera and the microscope stand via USB cables at the same time.

Functions such as the Light Manager, encoding and ECO mode are automatically launched.

Live images can also be viewed on the workstation and basic features in ZEN are available.

Functionality of the microscope:

- Light Manager
- Coded components
- ECO mode
- Image enhancement
- Observe live images
- Record and save images via software
- Basic features in ZEN

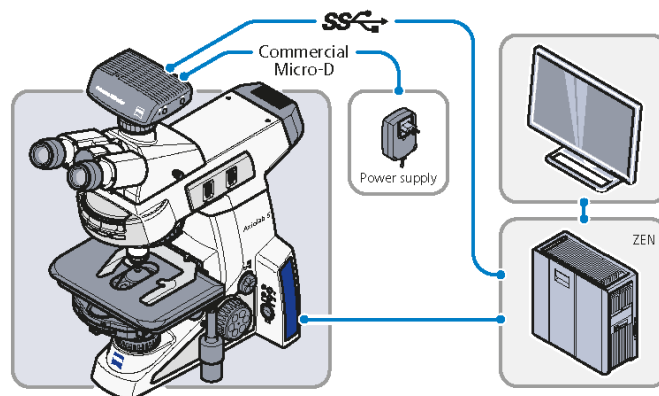
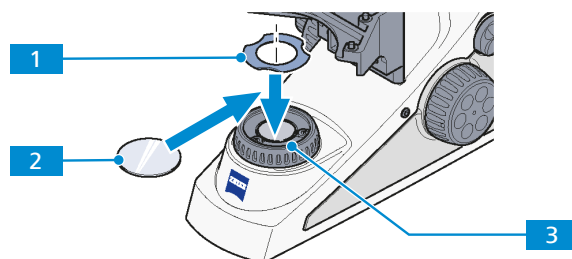

Fig. 54: Axiocam connected with ZEN software via a USB

10.11 Assembling the Filter 32x4 mm on the Luminous-field Diaphragm Operating Ring



1 Filter clamp

2 Filter

3 Luminous-field diaphragm operating ring

Procedure

1. If necessary, remove the filter clamp **1**.
2. Place the filter **2** on the luminous-field diaphragm operating ring.
3. To secure the filter, insert the filter clamp on the luminous-field diaphragm operating ring **3**.

Proceed in the reverse order for removal.

11 Revision History

Revision	Date of Issue	Introduced Modifications
9	04/2023	<ul style="list-style-type: none">▪ Editorial rework▪ Implementation of UKCA marking
8	05/2022	<ul style="list-style-type: none">▪ Implementation of revision history▪ Adaptation to Regulation (EU) 2017/746 (IVDR)

Tab. 2: Revision History

Glossary

BF (Brightfield)

Illumination and imaging system where direct light passes through the objective aperture and provides a bright background against which the image is viewed.

C-DIC

Differential Interference Contrast in circularly polarized light, a contrast method which employs the differential interference contrast technique with circularly polarized light, thus fully imaging sample structures which otherwise are only visible in a certain orientation

DF (Darkfield)

Illumination and imaging system that prevents direct light from entering the objective aperture.

DIC (Differential Interference Contrast)

An imaging light microscopy method that converts differences in the optical path length in the object into differences in the brightness of the image

FL (Fluorescence)

Phenomenon of a selective absorption of radiation with relatively short wavelength (i.e., relatively high energy) by matter with the result of the emission of radiation with longer wavelengths (i.e., lower energy), which persists only very briefly after the excitation has ceased.

RL (Reflected Light)

Designation for microscopy techniques to image light that was reflected by the object

TIC (Total Interference Contrast)

Total Interference Contrast in circularly polarized light is a technique for imaging and layer thickness measurement in materials microscopy. Contrary to traditional polarization interferometers, work in this technique is carried out in circularly polarized light.

TL (Transmitted light)

Light used for illuminating a object, where the light is transmitted through the object.

ZEISS Sales & Service Partner

The Sales & Service Partner is generally in the field for customer support in a regional area and / or a clearly defined customer group.

ZEISS service representative

Specially trained service expert, either ZEISS staff or authorized service partner of ZEISS.

ZEN

ZEISS Efficient Navigation

Index

A

Accessories	103
Air Conditioning and Quality	99
Ametropia	59
Analyzer slider	117
Aperture diaphragm	36, 123
Auxiliary microscope	50
Axiocam	136, 138
Axiolab 5 Bio-TL	19
Axiolab 5 Bio-TL/FL	20
Axiolab 5 Mat-TL/RL	22
Axiolab 5 Pol-TL	20
Axiolab 5 Pol-TL/conoscopy	21
Axiolab 5 Pol-TL/RL	21

B

Binocular photo tube	31, 32, 33, 106, 107
Binocular tube	105
installing	48, 49
Bireflectance	46
Birefringence	41, 70, 74
Brightfield	40, 45, 63, 78

C

Camera	136
installing	137
Filter carrier	
installing	123
Circular polarization contrast	43, 72, 78
Circular polarizer	120
Clamping device	38
installing	114
removing	113
Cleaning	
Water-soluble contaminations	90
Color filter carrier	119, 122
Components of the stand	23, 24, 25, 26, 27, 29
Condenser	36, 123
darkfield	53
installing	52, 53, 124
mounting	54
Condenser carrier	35
Darkfield condenser	
installing	53
Conoscopic observation	45
Connecting to the mains	57
Contamination	98
Cover	
installing	126, 130
removing	126, 130
Crystals, determining the optical character	44, 76

D

Darkfield	40, 46, 66, 81
Decontamination	98
Annular phase diaphragm	
centering	125
Darkfield diaphragm	
centering	125
DIC slider	123
Display elements	30
Disposal	98

E

ECO mode	62
Reversible eyecups	
installing	105
Eyepiece	34, 50
Eyepiece reticle	34
Eyepiece reticle	
adjusting for ametropia	59

F

Filter	119, 122
installing	143
Fluorescence	46, 84
Friction of coaxial knurled knobs of the stage	92
Fuse	
exchange	90

G

General Safety Information	12
----------------------------	----

H

Halogen lamp, replacing	127, 131
Hazard	
Biological hazard	15
Electrical hazard	14
Infection hazard	15
Skin irritation hazard	15
Voltage hazard	14
Hazards	14
Ergonomic	14
Prevention	14

I

Improper use	11
Intermediate plate	49
Interpupillary distance	59

K

Key functions	30
---------------	----

L

Lambda 4/plate	120
Lambda plate	119
Light Manager	
function	39
saving ratios	62
Switching Off	61
Switching On	61
Fluorescence light source	
exchanging LED	134
LED light source	
exchanging	128, 131
Low-power system	120
centering	121
installing	121

M

Mains connection	99
Mains, connecting to	57
Maintenance	88
interval	89
schedule	89
Mechanical stage	37, 91, 110, 111
adjusting the friction	92
installing	108
removing	109
setting the drive length	91
Modulator disk	
installing	55

N

Nosepiece	35, 51
-----------	--------

O

Objective	35, 51
centering	116
Operation	
Prerequisites	58
Optical character of crystals	44, 76
Optional system expansions	103
Installation	103

P

Path differences	43, 71, 76
Performance data	99
Permanent mode	62
Phase contrast	40, 69
Photo tube	31, 32, 33, 106, 107
Pinhole diaphragm	50
Polarization	41, 45, 69, 83
Polarization direction	41, 71, 75
Polarization contrast	
circular	72, 78
Polarizer	118, 119, 120
installing	123

Prerequisites

Operation	58
-----------	----

R

Reflected light	
brightfield	45, 78
darkfield	46, 81
fluorescence	46, 84
polarization	46, 83
Reflector turret	38
Reflector module	
installing	56
removing	57
Reflector turret	56
Requirements	
for Operators	12
Reticle	34
Rotary stage	38, 112
centering	115
installing	114
removing	113

S

Safe Operating Condition	12
Safety	11, 88
devices	17
interlocks	17
Sample guide	112
installing	114
removing	113
Sample holder	
installing	108
removing	109
Factory settings	96
Shutdown	97
Software	10
Spare parts	12
Specimen holder	37, 110, 111
Storage	97
Storage compartment	39
Switching off	87
Switching on	58

T

Tool	39
Training	12
Transmitted light polarization	45
transmitted light	
brightfield	40, 63
darkfield	40, 66
phase contrast	40, 69
polarization	41, 69
Transport	97
Troubleshooting	93
Tube	31, 32, 33, 105, 106, 107
assembling components	50

U

Unpacking	47
-----------	----

V

Viewing height	59
----------------	----

W

Warning	
labels	16
lights	16
Weight and Sizes	99

Z

ZEISS	
Portal	10
Service agreements	88

Carl Zeiss Microscopy GmbH
Carl-Zeiss-Promenade 10
07745 Jena
Germany

phone: +49 1803 33 63 34
fax: +49 3641 64 3439

info.microscopy.de@zeiss.com
www.zeiss.com/microscopy